



# ROTEX EHF SERIES ACTUATOR



SELF CONTAINED ELECTRO  
HYDRAULIC ACTUATOR

 **ROTEX**

*Engineering For The Future*

# ROTEX EHF SERIES ACTUATOR

*In continuation with the tradition of constant innovation and virtue in engineering, ROTEX, introduces the next generation compact, modular and for precise control,*

**Self Contained Electro-Hydraulic Actuator series "EHF"  
with 360° viewing GLOWDAPT dome indicator**



# WHY ROTEX?



## **Do you have leakages due to too many piping ?**

Rotex EHF has no external tubing for interconnecting different blocks, the only tubing is from frame to Actuator.



## **Do you spend more for modulating system for higher accuracy and lower dead-band ?**

Rotex EHF has unique PID with ADAPTIVE PID loop, providing accuracy, dead band less than 0.1 % using high performance solenoid valves.



## **Do you spend time in understanding the abbreviated menu and alarms ?**

Full featured LCD display, no abbreviations, no operating manual required.



## **Do you have problem in viewing open close indicators at night ?**

Special GLOWDAPT dome indicators, suitable for 360° viewing and visible at night.



## **Do you face operational failures due to moisture, vibration etc ?**

Rotex EHF is IP 68 and has Remote Mount capability up to 50 m.

## **ROTEX EHF Series**

solves all of the above problems and guarantees performance!!

## KEY FEATURES



### UNIQUE FEATURES FOR ON-OFF SYSTEM

- Linear ESD speed <1 sec for 50 mm travel
- Rotary ESD speed <1 sec
- Rotary system has built in transmitter
- Records events for 30 years

## FEATURES

- Completely self-contained. Single hydraulic block, no additional tubing between various hydraulic blocks.
- Modular design, for Linear, Rotary, On-off or Modulating.
- Fail close, or open by spring or using accumulator.
- Fail freeze function is achieved by using double acting actuator.
- ESD variants, logical or hard wired.
- Partial stroke through remote or using local panel.
- Full featured LCD for ease of installation, commissioning and operations.
- SIL 2, SIL 3 certified by EXIDA, as per IEC 61508:2010.
- Rotary actuator torque up to 600,000 Nm.
- Linear thrust up to 8,000 KN.
- Water and dust tight, IP 68 ( 10 m, 96 hour ).
- Monolithic, Weather proof or Ex d enclosure.
- Extended diagnostics for analysis available on network.
- Parametric setting for various applications.
- Communication network - HART, Modbus, Profibus DP, CAN OPEN, DeviceNet.
- Operating temperature, -50 °C to +70 °C.

## KEY FEATURES

### UNIQUE FEATURES FOR MODULATING

- +/- 0.1 % or better using unique adaptive PID controls
- <0.05 % using Proportional or Servo valves
- Redundant pumps and servo valve systems available
- Linear Positioning speed up to 0.2 sec per 25 mm
- Rotary positioning speed up to 0.8 sec for 90°

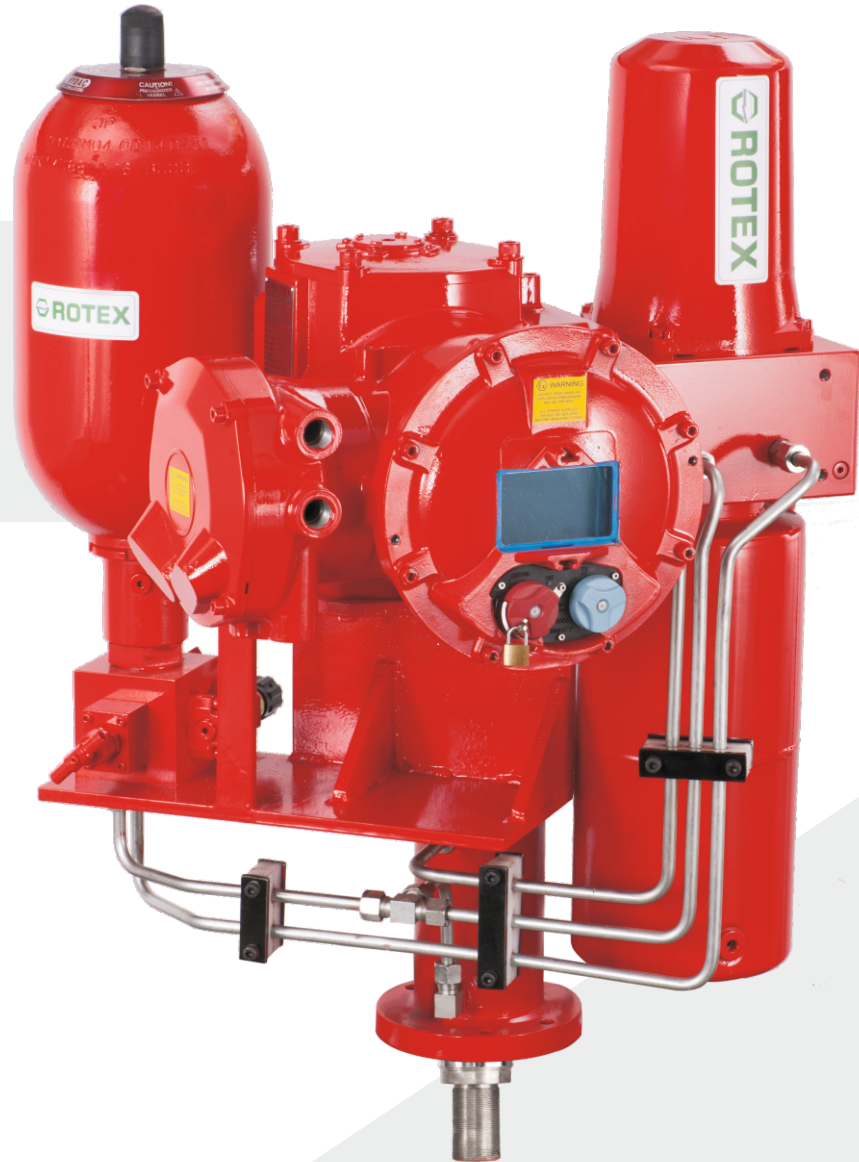

## FEATURES

- Completely self-contained. Single hydraulic block, no additional tubing between various hydraulic blocks.
- Modular design, for Linear, Rotary, On-off or Modulating.
- Fail close, or open by spring or using accumulator.
- Fail freeze function is achieved by using double acting actuator.
- ESD variants, logical or hard wired.
- Partial stroke through remote or using local panel.
- Full featured LCD for ease of installation, commissioning and operations.
- SIL 2, SIL 3 certified by EXIDA, as per IEC 61508:2010.
- Rotary actuator torque up to 600,000 Nm.
- Linear thrust up to 8,000 KN.
- Water and dust tight, IP 68 ( 10 m, 96 hour ).
- Monolithic, Weather proof or Ex d enclosure.
- Extended diagnostics for analysis available on network.
- Parametric setting for various applications.
- Communication network - HART, Modbus, Profibus DP, CAN OPEN, DeviceNet.
- Operating temperature, -50 °C to +70 °C.

## GRAPHICAL DISPLAY

- Large LCD display for better readability.
- No abbreviation or short form used.
- Operator may not need to refer manual for setting or calibration
- User friendly interface.
- On-screen display of diagnostics, alarms and error messages.
- Structured menu for parameters, setups and diagnostics.



## LOCAL CONTROL

- Lockable selector switches are provided on control module.
- The selector switch can be used for setting local/stop/remote selection and open/close.
- It can be used for configuration and for setting parameter.
- Allows manual operation.
- The red selector enables the operator to choose remote control, local control function and stop during operation.
- This selector switch can be locked in each position.



Selector to validate choice

Navigate through menu



## POSITION INDICATION LED'S

- 2 LEDs (red/green) indicate the position (close/open) at ends of travel, 3rd LED, Blue for faults.
- During operation, LED blinks depending on open or close cycle.
- Red and green LED can be freely assigned to open or closed positions.



## LOCAL MECHANICAL INDICATOR

- Local mechanical indication can be provided as an option.
- Shatterproof polycarbonate dome for visibility.
- Two piece unique indicator, ensures a life long visibility.



## GLOWDAPT

- The entire dome lights up RED or GREEN, depending upon the position.
- Shatterproof polycarbonate milky white dome.
- High luminous LED can be observed from a distance.





## POSITION MONITORING

### ROTARY

- ROTEX EHF series actuator are equipped with contactless feedback sensor
- 360° with freely rotating contactless feedback shaft.
- No dead angle. Can start anywhere and end anywhere.
- Contactless, high resolution feedback.
- Position feedback of 4-20 mA output signal, 0-10V optional.

### LINEAR

- Contactless feedback device.
- Stroke up to 1m.
- Speed up to 0.2 sec for 25mm..
- Position feedback of 4-20mA, 0-10V optional.

## END POSITION FEEDBACK

### ROTARY

- 4 micro-switch to detect open and close.
- Spring loaded cam for precise setting.
- Potential free contacts available at built in junction box.

### LINEAR

- Not installed on linear cylinder. It has to be installed in combination with product like damper etc and EHF.
- Contact ROTEX for further clarification.

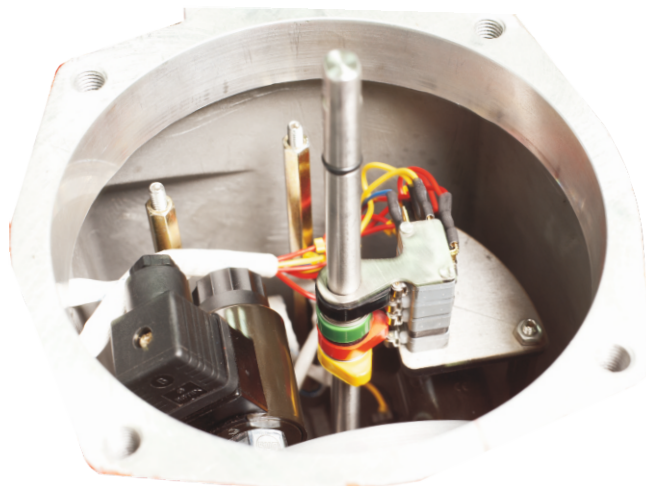

## PRESSURE MONITORING

- Actuator torque/force is measured based on pressure.
- Pressure transducer is integrated inside the hydraulic control system.
- Real time feedback from the pressure transducer is recorded and diagnostics information is generated based on parameterisation.
- It can detect over pressure, low pressure, "valve stuck", hydraulic failure, etc if any.
- 4-20 mA feedback signal proportional to actual torque of the valve is available as an option.

## ESD RESET

- ROTEX EHF series actuator has safety feature as built in priority.
- Once an ESD demand occurs, the actuator can reinstate only new command to operate or can be configured to manual reset through local controls via setting menu.
- This increases overall process and personal safety.

## FAIL FREEZE OPTION

- Main power supply is unreliable and is not part of functional safety.
- On failure of main power supply the operation of the actuator or the valve position is unaffected.
- ESD solenoid valve is separately powered through a 24 VDC ESD input signal and is solely responsible for safety function.

## EMERGENCY SHUTDOWN

- On demand emergency shutdown is the primary feature.
- ROTEX EHF system is suitable for use in SIS function in accordance to IEC 61508:2010.
- Suitable upto & including SIL 2 & SIL 3 capability.
- Can be configured through hardware for safety function or can be hardwired to perform fail-safe action.
- EHF can be configured to different failure requirements, please refer to the ordering code.
- On request, additional redundant solenoid valve can be provided.

## FAILSAFE OPTION

- Failsafe action can be performed based on following
  - On loss of ESD signal or ESD demand occurs
  - On loss of main power supply. In applications where main power is part of SIS.
- In both the above cases, the valve will be driven to its failsafe position in case of failure of main power supply or ESD demand.
- ESD Input signal - 20 to 60 VDC or 60 to 120 VAC, 110 to 220 VAC.

## DOUBLE SEAL COMPARTMENT

- Two barriers fitted with O-rings ensures optimum protection against water ingress into the electronic compartment.
- This protection remains effective even if the cover has not been closed properly or if the cable glands have not been tightened.
- Protection is also ensured for the local control selectors thanks to internal reed switches which prevent moisture ingress.
- Designed as per Ex e, IEC 60079-7.

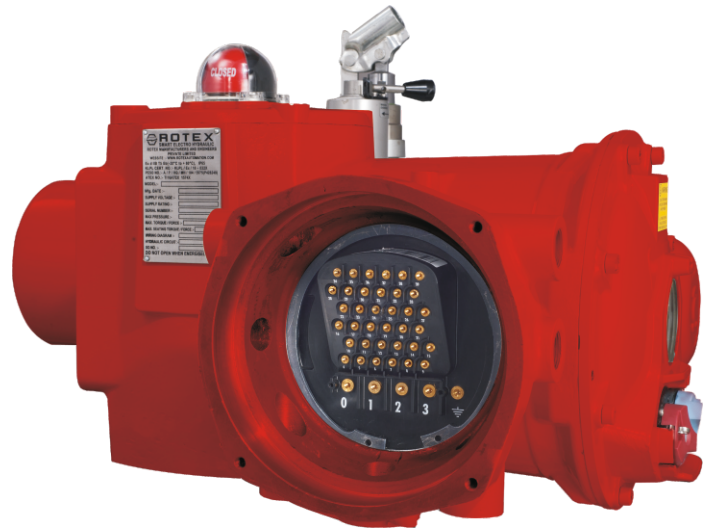

## REMOTE MOUNT

- Remote mount distance up to 50 m.
- IP67 remote mount unit, Ip68 available on request.
- Ideal for extreme environments and harsh conditions - high temperature, vibration, frequency and difficult to reach location.
- Shielded cable and circular connector ensures better connectivity and integrity.
- ROTEX remote mount unit is designed to move all electronics and hydraulics to remote location, ensuring correct functionality.

## NON-INTRUSIVE

- ROTEX EHF series actuator can be setup non-intrusively; pressure settings, torque and force rating can be set without opening any of the covers.
- Infrared communication - Intelli+® offers the possibility to communicate with a standard laptop through an infra-red link with INTELLI-KIT or INTELLIPOCKET.
- Bluetooth communication (option) - Bluetooth technology which uses radio signals to communicate between the PC.

## CONTROL LAYOUT

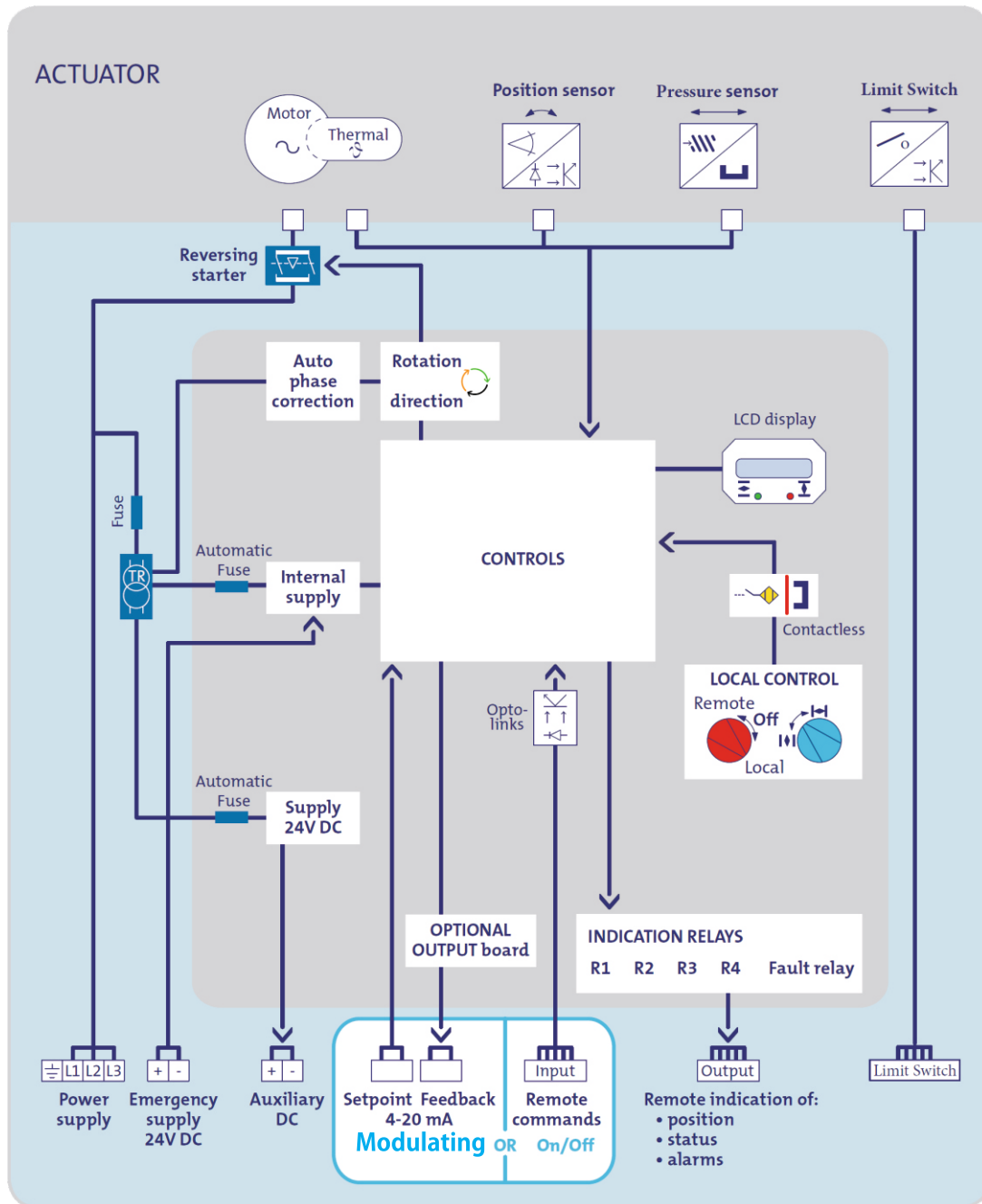

## CONTROL LAYOUT

- Strong and reliable electronics architecture.
- Epoxy painted to ensure long life against moisture ingress.
- Hardware, software are well proven using methodology softwares, validation softwares to avoid bugs and infinite loops.
- All integration goes through stringent quality checks to ensure long life.
- Potential free relays to support outputs and alarm configurations.

## PARTIAL STROKE TEST

Partial stroke test (PST) is a method to check, detect and ensure availability of safety function on demand. PST physically moves the valve to a predefined position, without affecting or disturbing the current process requirement.

Partial stroke test can prevent unexpected failure of safety function and provides information on current health status of valve and actuator.

- 30 records are maintained
- Can be conducted using local command switches
- ROTEX provides service to study the results and provide diagnosis

### Partial stroke test can be initiated through -

- Handheld
- Remote push button or binary input
- DTM / EDD using asset management system
- Pre-defined configured time interval

**ROTEX EHF series actuator has safety or demand as priority. Any other demands override the test.**

**Test will be aborted and returned to normal operation in case of-**

- Partial stroke fails
- Push button is held >5 seconds
- Safety DEMAND occurs

**Partial stroke test results can be saved and compared over the course of time.**

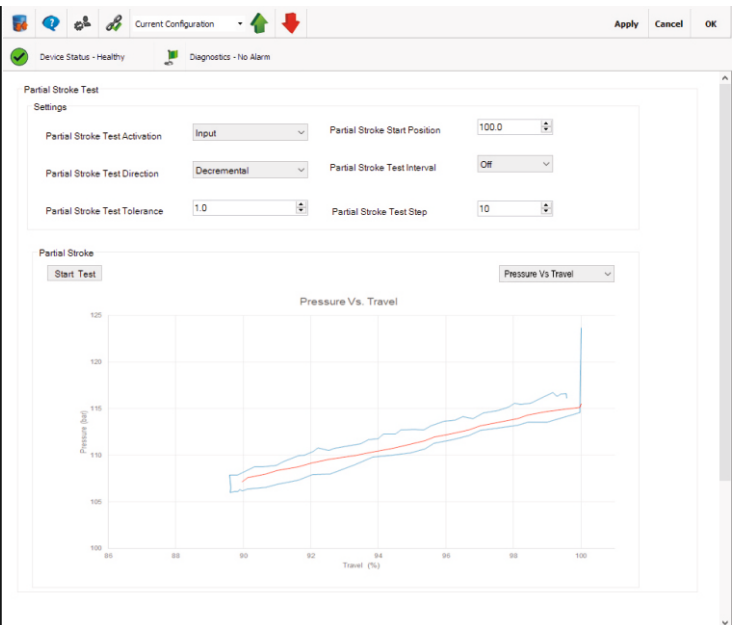

## DIAGNOSTICS

- Logical trend and histogram.
- Diagnostics with errors and recommendation.
- Alarm based on different threshold.
- On screen notification up to last 3 alarms or errors.
- Online monitoring.

## DIAGNOSTICS CAN IDENTIFY THE FOLLOWING ISSUES -

### Valve Faults

- Valve Clogging
- Valve seat or valve build-ups
- Seat erosion
- Increase in friction
- Valve tightness

### Actuator Faults

- Friction
- Spring failure
- Leakage through bush, diaphragm, seals, covers, connections

### Device Failure

- Electronics failure
- Pressure sensor failure
- Feedback sensor failure

### External Faults

- Unexpected change in supply pressure, (sudden drop or increase)
- Change in rate of flow or change in  $\Delta P$  across the valve

- Monitoring parameter can be configured with three different threshold levels.
- Each threshold level can be classified based on severity and generates a digital feedback signal, once triggered.
- Colour code represents nature of severity (can be communicated on HART to control system).
- This enables users to take necessary preventive action.



## COMMUNICATION

The fieldbus, present on a large number of installations, is used more and more to communicate information and commands with multiple actuators and devices wired in series on a single pair of wires. Thus, the number of information available from each actuator can be multiplied while reducing the overall cost of wiring on the site.

ROTEX EHF series actuators can be connected to most of the standard fieldbus available on the market:

- PROFIBUS DP
- FOUNDATION FIELDBUS
- MODBUS RTU
- HART
- Other Fieldbus on demand



For more security, redundant fieldbus ensures continuous operation, even in case of a bus line disruption. Indeed, all elements of the bus line (bus controller, lines, actuators interfaces) are doubled.

### OPEN VERSUS PROPRIETARY SYSTEMS:

Two physical concepts of fieldbus are available from various providers.

- The «Proprietary» so-called system: This is a technology designed by a device manufacturer for his own needs. A «Proprietary» system not only includes the actuators with the specific bus interface, but also the bus controller located at the line head-end. Only the products proposed by the bus controller manufacturer can be installed on the bus.
- «Open» systems: One using standard international fieldbuses so various manufacturers can supply compatible controllers and interfaces. This type of technology is proven, reliable and offers fast response time.

## COMMUNICATION

ROTEX in collaboration with BERNARD CONTROLS chooses the «open» system for its fieldbus solutions.



- Based on robust PLC technology and open fieldbus protocol.
- Up to 120 actuators and 10km distance.
- Fast response time. Standard scan time 1 to 3 s whatever the distance and number of actuators connected.
- 1 to 3 lines starts.
- Simple or redundant configurations.
- Overall start up time reduced to the minimum.



## SCHEMATICS

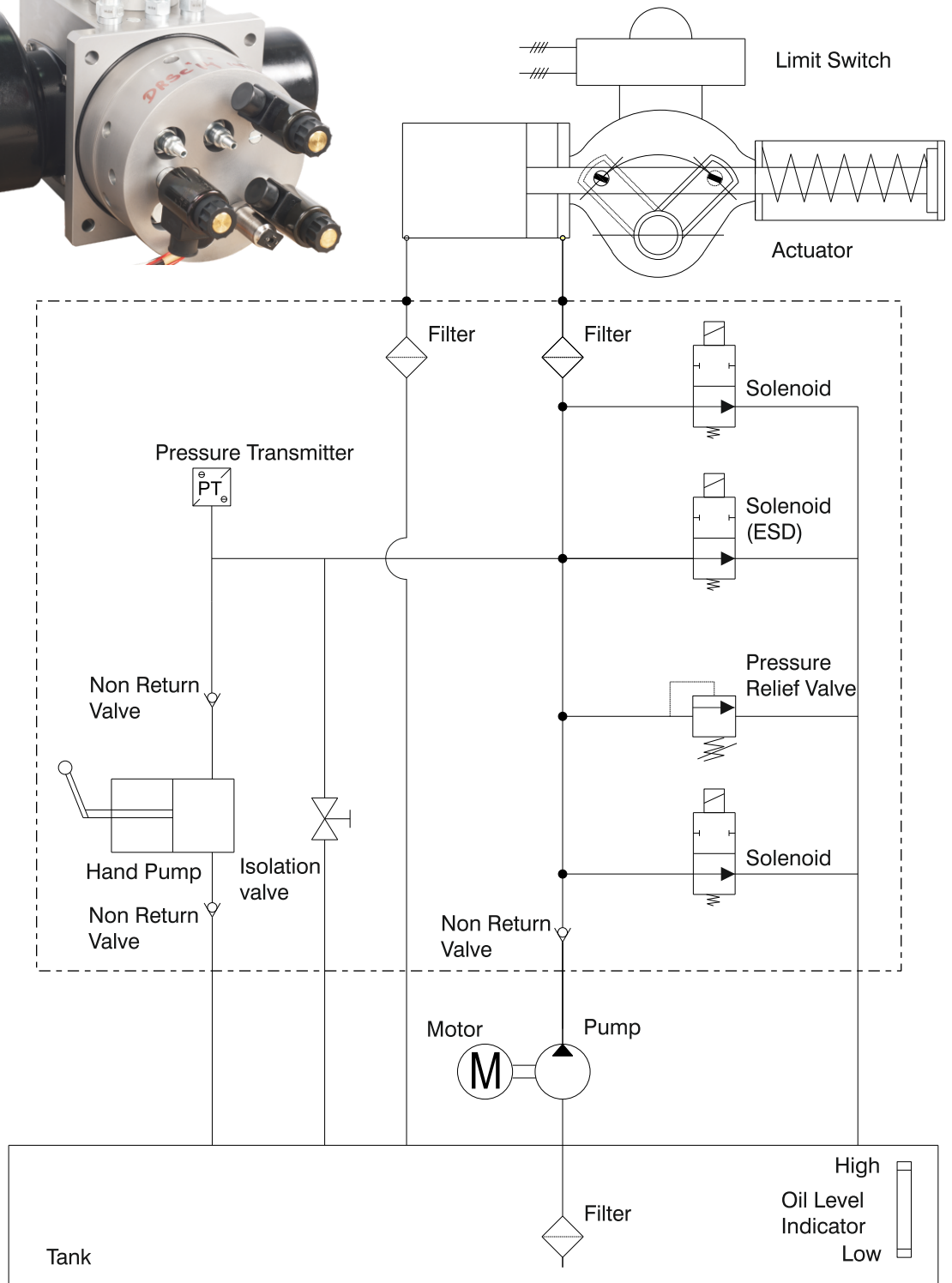

# SCHEMATICS

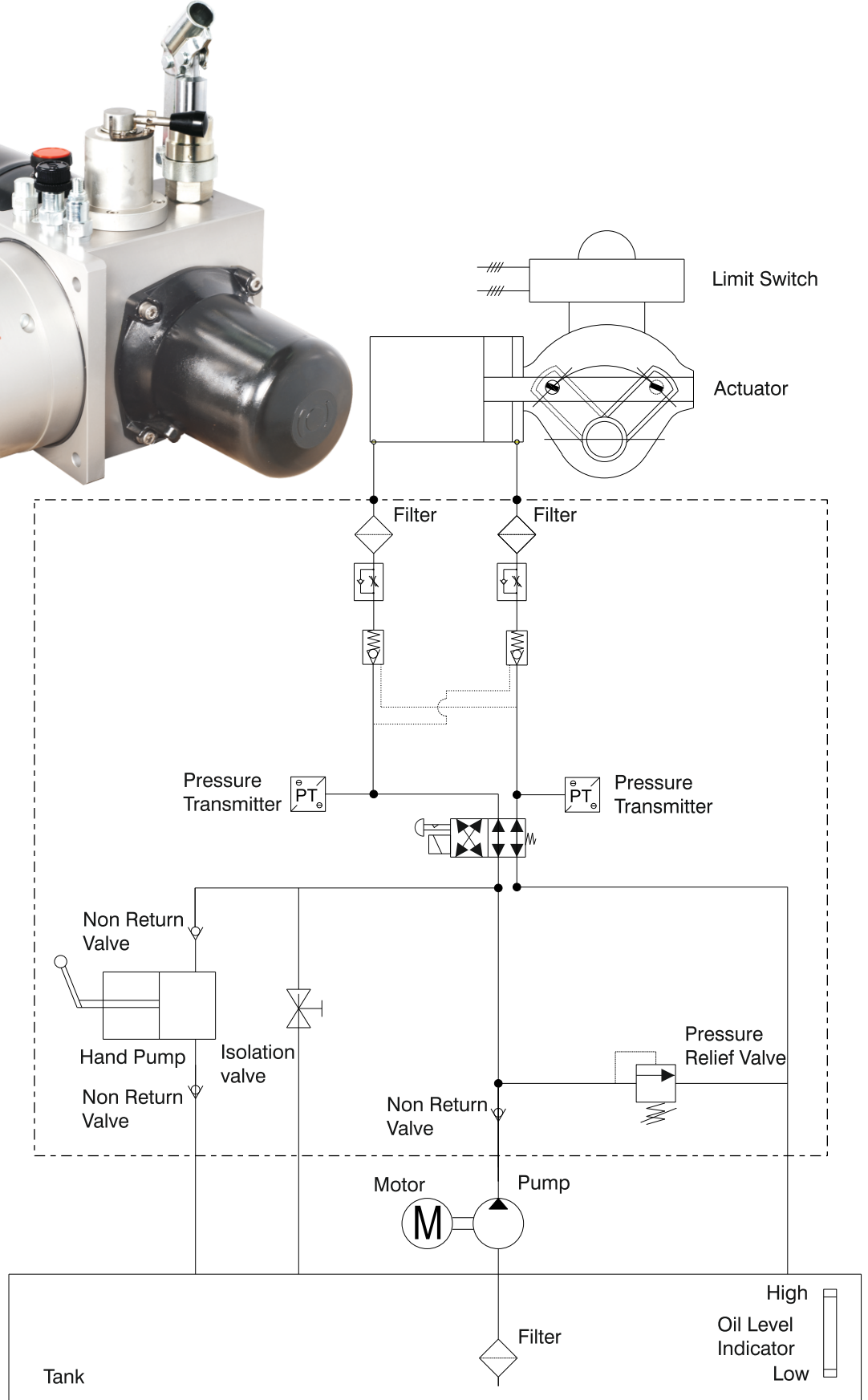

## TECHNICAL SPECIFICATIONS

TORQUE RANGE	Torque	25 to 6,00,000 Nm for rotary and 1.2 to 8000 kN force for linear actuator
ENCLOSURE PROTECTION	Construction	Casting: Cast Aluminium, Aluminium Alloy, etc. Actuator: Refer Actuator Catalog
	Ingress Protection	IP65, optional IP68 10m/96h
	Controls Location	As a standard, the controls are integral to the electrohydraulic head. Optionally, the head can be mounted at a separate location (maximum distance between actuator and controls = 50m and needs hydraulic tubing and electrical wiring).
	Explosion Proof ATEX	ATEX Directive 94/9/EC - CENELEC EN 60079-0, EN 60079-1, EN 13463, IS 60079 As standard: Ex d II B T4 (option T5 or T6) and Ex tb IIIC T135°C (option T100°C, T85°C) On request: Ex d II C T4 (option T5 or T6)
	Explosion Proof IEC Ex	IEC Ex - standard IEC 60079-0, IEC60079-1, EN13463 As standard: Ex d II B T4 (option T5 or T6) and Ex tb IIIC T135 °C (optional T100 °C, T85 °C) On request: Ex d II C T4 (option T5 or T6)
	Ambient Temperature Operating Range	<ul style="list-style-type: none"> <li>• IIB standard: - 20 °C ... +70 °C</li> <li>• IIB low temperature option: - 60 °C ... +70 °C</li> <li>• IIC option: - 20 °C ... +70 °C</li> </ul>
	External Corrosion Protection	Standard paint system: Polyuréthane paint RAL3020 complying with ISO 12944 up to C5M Optional special anti-corrosion protection for marine, aggressive or abrasive atmospheres All cover fasteners captive and stainless
	Double Sealing Protection	The control section of the actuator is totally isolated from the terminal compartment to protect electronic components
MOTOR	Motor Technology	<ul style="list-style-type: none"> <li>• AC motor, single or three-phase TENV type, completely enclosed, non ventilated squirrel cage motors, Class F insulated with integral thermal overload protection</li> <li>• AC motor, Class F insulated, integral thermal overload protection, 24V DC, optionally other voltages available</li> </ul>

## TECHNICAL SPECIFICATIONS

MECHANICAL SPECIFICATIONS	Manual override	Hydraulic handpump, equipped with Hydraulic AUTO/MANUAL valve
	Vibration Resistance	1g (9.8 m/s <sup>2</sup> ) at 10-500 Hz (Contact ROTEX for higher vibration levels)
	Lubrication	Actuators are lubricated for product lifetime and do not require any specific periodic maintenance
ELECTRICAL SPECIFICATIONS	Power Supply	<p>The actuators can operate on a wide variety of power supplies:</p> <ul style="list-style-type: none"> <li>• Single-phase: 110, 120 &amp; 230 V - 50/60 Hz</li> <li>• Three-phase: 380, 400, 415, 440, 480, 575, 690 V - 50/60 Hz</li> <li>• DC: 24 V, optionally other voltages available</li> <li>• Voltage tolerance: ±10%; Applies for rated torque performance; duty cycle and speed is not guaranteed</li> <li>• Frequency tolerance: ±5%; Applies for rated torque performance; duty cycle and speed is not guaranteed</li> <li>• Maximum starting volt drop: -15%; Actuators capable of starting and running up to speed</li> </ul>
	Cable Entries	<p>Maximum available configurations:</p> <ul style="list-style-type: none"> <li>• M32 X 1.5 X 1 No. and M25 X 1.5 X 6 Nos.</li> <li>• 1 1/4" NPT X 1 No. and 3/4" NPT X 6 Nos.</li> </ul>
	Electrical Connection	<ul style="list-style-type: none"> <li>• Ring tongue terminals</li> <li>• Internal and external ground points</li> </ul>
POSITION AND PRESSURE SENSORS	Position	<ul style="list-style-type: none"> <li>• Contactless sensor</li> <li>• Potentiometer (Optional)</li> </ul>
	Pressure	<ul style="list-style-type: none"> <li>• Transmitter connected to controller for feedback and logic.</li> </ul>

## TECHNICAL SPECIFICATIONS

CONTROLS	Power Circuit	Built-in phase reversal and failure detection
	Display	Modern LCD display
	On-off Remote Control (Hardwired Control)	Command by <ul style="list-style-type: none"> <li>• Voltage: 10 to 250V DC/AC (current: 1Amp at 24V)</li> <li>• Dry contact (use controller auxiliary 25 VDC supply) isolated by opto-couplers</li> <li>• Auto latching minimum pulse duration: 100ms</li> </ul>
	Signaling Relays	<ul style="list-style-type: none"> <li>- 4 relays, each can be freely configured</li> <li>• Contact configuration: normally open or normally closed</li> <li>• Minimum current 10mA at 5V</li> <li>• Maximum current 5A at 250V AC or 5A at 30VDC (resistive load)</li> <li>• Optionally, additional 3 relays available</li> </ul>
	Fault Relay	<ul style="list-style-type: none"> <li>• 8 relays, each can be freely configured</li> <li>• Normally closed &amp; energized SPDT contact</li> <li>• Minimum current 10mA at 5V</li> <li>• Maximum current 5A at 250V AC or 5A at 30VDC (resistive load)</li> <li>• Optionally, additional 3 relays available</li> </ul>
	Analogue Control	Input (setpoint) and output (feedback) signals are fully isolated from each other Signal configurations (selectable): <ul style="list-style-type: none"> <li>• Input signal: 4-20 mA - output signal: 4-20mA</li> <li>• Input signal: 0-20 mA - output signal: 0-20mA</li> <li>• Input signal: 0-10 V - output signal: 0-20mA (0-10V with an external resistance)</li> </ul> Analogue inputs: <ul style="list-style-type: none"> <li>• in current: impedance of 160 Ohms</li> <li>• in voltage: impedance of 11 KOhms</li> </ul> Analogue outputs: <ul style="list-style-type: none"> <li>• in current: maximum acceptable load of 750 Ohms at 24 VDC supply</li> <li>• In voltage: minimum acceptable load of 50 KOhms (with a shunt resistance of 500 Ohms)</li> </ul>
	Transmitter (Option)	<ul style="list-style-type: none"> <li>• Position (4-20 mA), Pressure (4-20 mA),</li> <li>• Temperature (4-20 mA) and Level (4-20 mA).</li> </ul>
	Limit Switches	<ul style="list-style-type: none"> <li>• Standard 2, max 4 mechanical limit switch (SPDT): 120/230 VAC or 30 VDC</li> <li>• Proximity limit switch NO/NC (optional): 5-60 VDC</li> </ul>
	Fire Protection (Option)	<ul style="list-style-type: none"> <li>• 30 minutes at 1,000 °C</li> <li>• Tested to UL1709 criteria</li> </ul>

## TECHNICAL SPECIFICATIONS

SETTINGS	Settings	Non-Intrusive. All actuator settings and parameters are stored in a non-volatile EEPROM memory. Protection by password. Can be done by local command, infrared link or optional bluetooth link (For operational and functional safety, bluetooth link is limited to 10m)
	Local Selectors	The Controller can be fully set via its local display and does not require any specific setting tool
	INTELLI+ KIT (Option)	<ul style="list-style-type: none"> <li>• INTELLI+ SOFT CD-ROM for laptop PC</li> <li>• Infrared module to connect to the laptop (USB) and clip on the actuator window</li> </ul> From update 3.00, INTELLI+ SOFT is also able to manage bluetooth link with advanced torque recordings
	INTELLI+ Pocket (Option)	Industrial pocket PC (PDA) <ul style="list-style-type: none"> <li>• Protection: IP65 (option: ATEX II2G EEx ia IICT4)</li> <li>• Shock resistance: 1.2 m (on concrete)</li> <li>• Communication:               <ul style="list-style-type: none"> <li>- with INTELLI+ : Infrared link (40 cm maximum distance)</li> <li>- with PC: bluetooth, IRDA, Wifi (802.11b) as a standard</li> </ul> </li> <li>• Optional USB station.</li> <li>• Operating system: Windows Mobile 2005, 64Mb RAM + 256Mb storage card</li> </ul>
FIELD BUS CONTROLS	Profibus DPV1 (Option)	<ul style="list-style-type: none"> <li>• PROFIBUS-DPV1 - RS 485</li> <li>• Baud rate: 9.6 kbit/s up to 1.5 Mbit/s (autodetection)</li> <li>• Communication protocol: PROFIBUS DPV1 slave-cyclic &amp; acyclic</li> <li>• Type of connection: single line (standard) or redundant line (option)</li> <li>• Cable specification: Profibus certified cable only</li> <li>• Line connection without repeater               <ul style="list-style-type: none"> <li>- Actuators per line: 31 max.</li> <li>- Line length: 1.2 km max. (0.75 mi)</li> </ul> </li> <li>• Line connection with repeaters               <ul style="list-style-type: none"> <li>- Number of repeaters per line: 9 max</li> <li>- 30 actuators and 1 Km max. per segment .</li> <li>- Number of actuators per line with repeater: 124 maximum</li> <li>- Line length with 9 repeaters: 10.2 km max. (6.2 mi)</li> </ul> </li> <li>• Scan speed (30 units &amp; 1.2 km): 0.1s (at a baud rate of 93.75 Kbit/s)</li> <li>• Power supply: internal and isolated via INTELLI+®. Optional signaling battery or 24VDC external backup supply update the open and closed position information in case of loss of power supply</li> <li>• Technical approval: operability approved by PNO (Profibus Nutzer Organisation)</li> </ul>

## TECHNICAL SPECIFICATIONS

<b>FIELDBUS CONTROLS</b>	Modbus (Option)	<ul style="list-style-type: none"> <li>• MODBUS RTU - RS 485</li> <li>• Transmission medium: 1 shielded pair cable</li> <li>• Functions: Half Duplex, asynchronous mode, multidrop</li> <li>• Baud rate: 1.2k to 115 Kbit/s</li> <li>• Format: 8 data bits, 1 stop bit, no parity</li> <li>• Communication protocol: Modbus (slave)</li> <li>• Modbus address: configurable by the actuator menu</li> </ul>
	Foundation Fieldbus (Option)	<ul style="list-style-type: none"> <li>• H1 speed = 31.25kBit/s</li> <li>• Fully compliant with fieldbus standard IEC 61158</li> <li>• Physical layer: IEC 61158-2, 2 wires communication</li> <li>• Current consumption: 20mA</li> <li>• Operating voltage: 9 to 32 VDC</li> <li>• Cable specification: Type A (for example: 3076F Belden)</li> <li>• Line connection             <ul style="list-style-type: none"> <li>- Actuators per line without repeater: 31 max.</li> <li>- Line length without repeater: 1.9 km max. (1.2 mi)</li> <li>- Number of repeaters per line: 4 max.</li> <li>- Maximum number of actuators and line length depends on consumption available</li> </ul> </li> <li>• Technical approval: Foundation tested. Several DCS manufacturer operability checked.</li> </ul>
	Hart (Option)	<ul style="list-style-type: none"> <li>• Interface: HART, 4-20mA current, FSK modulation</li> <li>• Transfer speed: 1.2 kbit/s</li> <li>• Protocol: HART 7.4</li> <li>• Impedance: 250 Ohms</li> <li>• Power consumption: Internal by Intelli+ transformer, External power supply for 4-20mA loop only</li> <li>• Actuator configuration: Available through EDD file</li> <li>• Connection line: Point-to-Point or Multi-drop</li> <li>• Technical approval: approved by Hart Communication Foundation</li> </ul>

## APPLICATIONS

### EHF FOR CROSS COUNTRY PIPELINE.

- 24 VDC generated through solar panel
- Solar panel suitable for safe area or for “Ex” classification area.
- Unique power pack running on 24 VDC.
- Power module with battery charge having back up up to 3 strokes and 8 days working without sunlight
- Ranging from 10,000 Nm to 197,500 Nm



## OTHER APPLICATIONS

### ON – OFF

Emergency Shutdown:

- Gas gathering stations
- Cross country pipeline
- Pump non return valve
- Coal and ash dampers

### MODULATING

- HP and LP bypass valve
- Water spray and main valve
- Control valve for severe service
- Butterfly valve for coke oven batteries
- General purpose modulating valves



## ORDERING CODE

**1**

Product Series	
Code	Description
EHF	Electro-Hydraulic Systems

**2**

Operation Type	
Code	Description
LO	Linear -On/Off
RO	Rotary - On/Off
LM	Linear -Modulating
RM	Rotary - Modulating

**3**

Actuator Size	
Code	Description
	#Refer Actuator sizing

**4**

Main Power Supply	
Code	Description
A	24 VDC
B	110/120 VAC 50Hz
C	110/120 VAC 60Hz
D	220/240 VAC 50Hz
E	220/240 VAC 60Hz
F	220/240 VAC 50Hz, 3 Phase
G	220/240 VAC 60Hz, 3 Phase
H	380 VAC 50Hz, 3 Phase
I	380 VAC 60Hz, 3 Phase
J	400 VAC 50Hz, 3 Phase
K	400 VAC 60Hz, 3 Phase
L	415 VAC 50Hz, 3 Phase
M	415 VAC 60Hz, 3 Phase
N	440 VAC 50Hz, 3 Phase
O	440 VAC 60Hz, 3 Phase
P	480 VAC 50Hz, 3 Phase
Q	480 VAC 60Hz, 3 Phase
R	575 VAC 50Hz, 3 Phase
S	575 VAC 60Hz, 3 Phase
T	690 VAC 50Hz, 3 Phase
U	690 VAC 60Hz, 3 Phase

**5**

Fail-Safe	
Code	Description
SP	Fail safe condition achieved using spring
	Fail safe condition achieved using accumulator
AC	Fail safe condition achieved using accumulator
*	None

**6**

Fail-Safe Condition	
Code	Description
STY	Stayput
EFO	Signal/ESD Fail - Open, Power Fail - Stayput
	Signal/ESD Fail - Close, Power Fail - Stayput
EFC	Signal/ESD and Power Fail - Close
EPO	Signal/ESD and Power Fail - Open
PFC	Power Fail - Close
PFO	Power Fail - Open

**7**

ESD Configuration	
Code	Description
A	24 VDC Single SOV
B	24 VDC Dual SOV, Redundant
C	110 VAC Single SOV
D	110 VAC Dual SOV, Redundant
E	230 VAC Single SOV
F	230 VAC Dual SOV, Redundant
*	None

**8**

Closing Speed	
Code	Description
XXX	0.2 - 300 seconds
	For other closing speed contact ROTEX

**9**

Accumulator	
Code	Description
*	None
P	Piston Type
B	Bladder Type

**10**

Manual Override	
Code	Description
*	None
H	Handpump
S	Handpump SS

**11**

Cable Entries#	
Code	Description
TR0	1 1/4" NPT (F) X 1 No., 3/4" NPT X 6 Nos
6M0	M32 X 1 No., M25X1.5 X 6 Nos
TR1	1 1/4" NPT (F) X 1 No., 3/4" Adapted to 1/2" NPT (F) - Qty 6
6M1	M32 X 1 No., M25 Adapted to M20 x 1.5 - Qty 6
4M0	M25 X 2, M20 X 4
TR2	1 1/4" NPT X 1 No., 1" NPT Adapted to 1/2" - Qty 6

## ORDERING CODE

### 12

Indicator	
Code	Description
*	None
M	Mechanical
L	ROT-GLOW LED Illumination

### 13

Limit Switch	
Code	Description
*	None
1A2	2 SPDT Microswitches
1A4	4 SPDT Microswitches
3A2	Proximity NBB3-V3

### 14

Transmitter (4 ... 20 mA Feedback)	
Code	Description
*	None
P	Position Transmitter
R	Pressure Transmitter
B	Position + Pressure Transmitter

### 15

Oil Transmitter (4 ... 20 mA Feedback)	
Code	Description
*	None
T	Oil Temperature Transmitter
L	Oil Level Transmitter
O	Oil Temperature + Level

### 16

Temperature	
Code	Description
*	-20 °C to +50 °C
Ht1	-20 °C to +70 °C
Lt1	-30 °C to +50 °C
Ht2	-30 °C to +70 °C
Lt2	-40 °C to +50 °C
Ht3	-40 °C to +70 °C
Lt3	-50 °C to +50 °C
Lt4	-50 °C to +70 °C
	for temperature above +70 °C, select remote mount units

### 17

Communication	
Code	Description
*	None
F	Foundation Fieldbus
H	Hart
M	Modbus
P	Profibus

### 18

Certification	
Code	Description
*	None / Weather Proof
C1	Exd, IS 60079-1
C2	Exd, IS 60079-1 + PESO
C3	Exd, IS 60079-1 + SIL 3
C4	Exd, IS 60079-1 + PESO + SIL 3
C5	SIL 3
C6	ATEX IEC 60079-1
C7	IECEX IEC 60079-1
C8	ATEX IEC 60079-1 + SIL 3
C9	IECEX IEC 60079-1 + SIL 3

### 19

Mounting	
Code	Description
*	Vertical stem, Horizontal Pipeline, Actuator Parallel to Pipeline
M1	Vertical stem, Horizontal Pipeline, Actuator Perpendicular to Pipeline
M2	Horizontal stem, Horizontal Pipeline, Actuator Parallel to Pipeline
M3	Horizontal stem, Horizontal Pipeline, Actuator Perpendicular to Pipeline
M4	Horizontal stem, Vertical Pipeline, Actuator Parallel to Pipeline
M5	Horizontal stem, Vertical Pipeline, Actuator Perpendicular to Pipeline For Linear application, M1, M3, and M5 Available

### 20

Special Version	
Code	Description
*	None
RM50	Remote Mount 50 Metres

## DIMENSIONAL DRAWING

### ROTARY

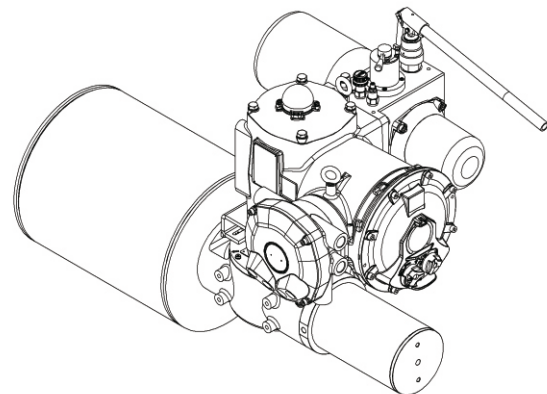
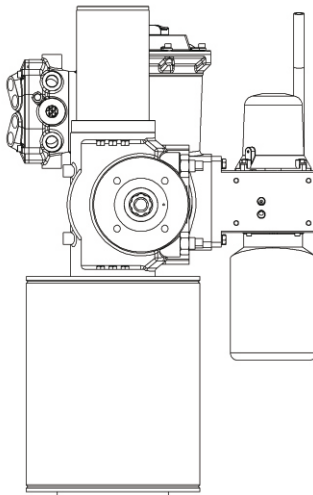
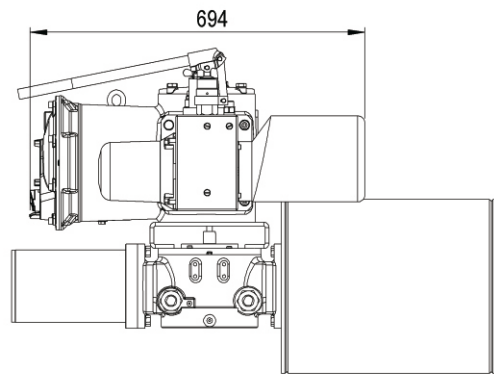
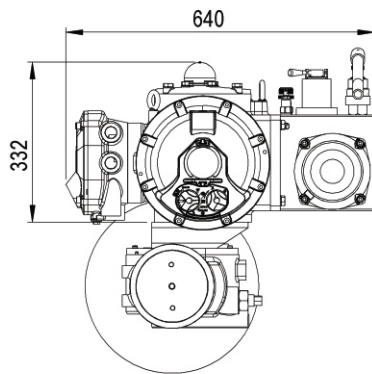

ALL DIMENSIONS ARE IN MM

LINEAR

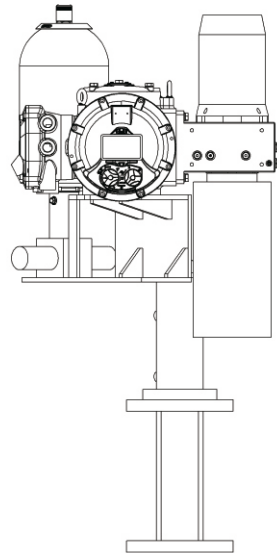
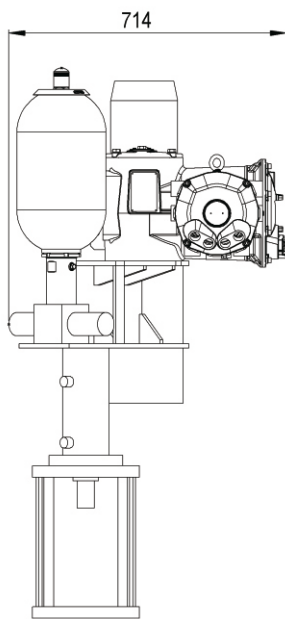
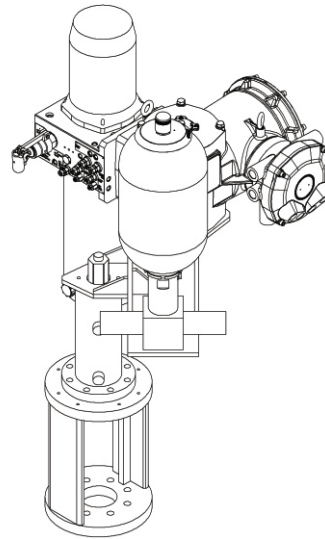
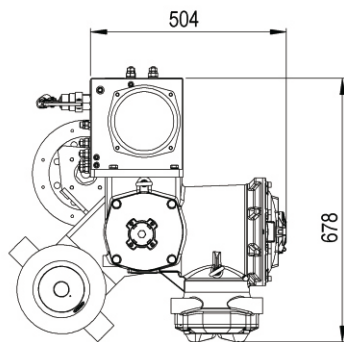

ALL DIMENSIONS ARE IN MM



*Engineering For The Future*

ROTEX GROUP SALES HEAD QUARTER  
B/703/704, Western Edge-II, Off Western Express Highway,  
Borivli (East), Mumbai-400066  
Phone : +91 22 42111444  
Fax : +91 22 42111400  
Email : sales-bby@rotexautomation.com

ROTEX MANUFACTURERS AND ENGINEERS PRIVATE LIMITED  
Plot No. R-852 / 853, TTC Industrial Area, Rabale, Navi Mumbai- 400701  
Phone : +91 22-20871065 / 66 / 67 / 68  
Email : rmepl@rotexautomation.com

ROTEX AUTOMATION EUROPE  
Bierstraat 117  
3011 XA Rotterdam  
The Netherlands  
Phone : +31-88-5053505  
E-mail : europe@rotexautomation.com