

ROTEX

SERVICE INSTRUCTIONS

FOR MODELS DRV SERIES

DRV250 TO DRV700

PNEUMATIC ACTUATORS

REVISION: "0"

DATE: 10TH OCT 2008

SECTION 1 - INTRODUCTION

1.1 GENERAL SERVICE INFORMATION

1.1.1 This service procedure is offered as a guide to enable general maintenance to be performed on **Rotex** DRV250, DRV300, DRV400, DRV500, DRV600, DRV700, Double Acting and Spring Return Series Pneumatic Actuators.

1.1.2 Normal recommended service interval for this actuator series is five years.

NOTE: Storage time is counted as part of the service interval.

1.1.3 This procedure is applicable with the understanding that all pneumatic pressure has been removed from the actuator.

1.1.4 Remove all piping and mounted accessories that will interfere with the module(s) that are to be worked on.

1.1.5 This procedure should only be implemented by a technically competent technician who should take care to observe good workmanship practices.

1.1.6 Numbers in parentheses, () indicate the bubble number (reference number) used on the **Rotex** Assembly Drawing and Actuator Parts List.

1.1.7 When removing seals from seal grooves, use a commercial seal removing tool or a small screwdriver with sharp corners rounded off.

1.1.8 Use a non-hardening thread sealant on all pipe threads.

CAUTION: Apply the thread sealant per the manufacture's instructions.

1.1.9 **Rotex** recommends that disassembly of the actuator modules should be done in a clean area on a workbench.

1.2 **DEFINITIONS**

WARNING: If not observed, user incurs a high risk of severe damage to actuator and/or fatal injury to personnel.

CAUTION: If not observed, user may incur damage to actuator and/or injury to personnel.

NOTE: Advisory and information comments provided to assist maintenance personnel to carry out maintenance procedures.

1.3 **GENERAL SAFETY INFORMATION**

Products supplied by **Rotex**, in its "as shipped" condition, are intrinsically safe if the instructions contained within this Service Instruction are strictly adhered to and executed by well-trained, equipped, prepared and competent personnel.

WARNING: For the protection of personnel working on Rotex actuators, this procedure should be reviewed and implemented for safe disassembly and reassembly. Close attention should be noted to the **WARNINGS, CAUTIONS** and **NOTES** contained in this procedure.

1.4 **ROTEX REFERENCE MATERIALS**

1.4.1 Cross sectional assembly drawing for Double acting Actuator.

1.4.2 Cross sectional assembly drawing for Spring return Pneumatic Actuator.

1.5 SERVICE SUPPORT ITEMS

1.5.1 Seal kit.

1.5.2 Bearings

SECTION 2 - ACTUATOR ASSEMBLY

2.1 GENERAL DISASSEMBLY

WARNING: It is possible, that the actuator may contain a dangerous gas and/or liquids. Ensure that all proper measures have been taken to prevent exposure or release of these types of contaminants before commencing any work.

2.1.1 Actuator assembly is written to either completely disassemble the entire actuator or can be used to disassemble individual Modules as needed (Pneumatic cylinder or spring retainer assembly, etc.).

WARNING: DO NOT REMOVE SPRING RETAINER ASSEMBLY WHILE SPRING IS COMPRESSED.

2.1.2 When the spring retainer assembly is to be removed it should be removed from the central block(49) drive assembly prior to the Pneumatic cylinder assembly removal or disassembly.

2.1.3 To ensure correct reassembly, mark or tag mating surfaces.

2.1.4 Actuator central block(49) base should be rigidly mounted before assembly of any component

2.2 DOUBLE ACTING ACTUATOR ASSEMBLY

WARNING: If not already removed disconnect all operating pressure from actuator power cylinders for disassembly.

WARNING: The spring cartridge must be checked to verify that the spring(s) are in their extended position before the spring retainer assembly is disassembled from the central block(49) drive assembly. This can be checked by verifying stroke adjustment screw are not in tension.

2.2.1 Fix central block(49) on rigid fixture, clean it properly put some grease and insert bearing(32) as shown. Insert oring(42) in pinion(16) and place it into bottom bearing(32) in central block(49).

2.2.2 Assemble a rack(17) and pinion(16) as marking shown on both and insert bearing(32) into pinion(16). Fit pinion insert(8) on pinion(16) by screw(38) and insert oring(43) into it.

2.2.3 Take a sleeve(13), insert two bearing(31), put spacer(5) and again insert two bearing(31) and fix it with internal circlip(47), insert offset roller(9) from circlip side and fix another end with external circlip(33). Make two set of offset roller assembly and insert it into central block(49) such that both assemblies should guide rack(17).
Screw(52) them with central block(49) from bottom, do not tighten the screw(52).

2.2.4 Insert both stroke adjustment screw(11) into central block(49), insert oring(50) and nut(35).

2.2.5 Connect piston rod(2) to rack(17) at right hand side while facing stroke adjustment screw(11) for CCW and left hand side for CW, with connecting nut(7) and bolt(12) as

shown in assembly drawing. Connect connecting rod1(6) to other side of rack(17) same as piston rod(2). Insert bearing bush(4) in central block(49) through piston rod(2) and connecting rod1(6).

2.2.6 Place gasket(54) onto central block(49) and fit central block cover(14), ensure that top of offset roller(9) is get inserted into central block cover(14), then tighten it by screw(36).

2.2.7 Set the stroke adjustment screw(11) for 0 and 90 degree.

2.2.8 Insert lip seal for piston rod(3) in cover front end(20),insert gasket(55) and fit it on central block(49) with screw(37) from piston rod(2) side. Insert oring(45) in cover front end(20).

2.2.9 Fit piston(19) to piston rod(2) with screw(40), insert lip seal(21) into piston(19) from both side with lip opening towards pressure direction. Place properly greased piston strip(46) on piston(19).

2.2.10 Apply layer of grease on honed portion of tube(1), insert it in piston(19).

2.2.11 Insert tie rod(10) from cover front end(20) fit nut(34) from front side.

2.2.12 Insert oring(45) in cover rear end(18) and assemble it with tube(1) and tie rod(10) by nut(34).

2.2.13 Insert oring(51) in top cover(15) and fit it with central block cover(14) by screw(36). Fit plug cover(53) on central block cover(14).

2.2.14 Place gasket(55) and fit cover for connecting rod1 to other side of central block(49).

2.3 SINGLE ACTING ACTUATOR ASSEMBLY

- 2.3.1 Follow the same procedure of double acting assembly. Remove cover for connecting rod1.
- 2.3.2 Insert oring(44) in E cover front end(28) and connect it to central block(49) by screw(37).
- 2.3.3 Connect spring cartridge to connecting rod1(6).
- 2.3.4 Place E tube(26) on spring cartridge, insert tie rod(24) from E cover front end(28), insert nut(34) and assemble E cover rear end(29) to E tube(26), connect it with tie rod(24) and fit it with nut(34).

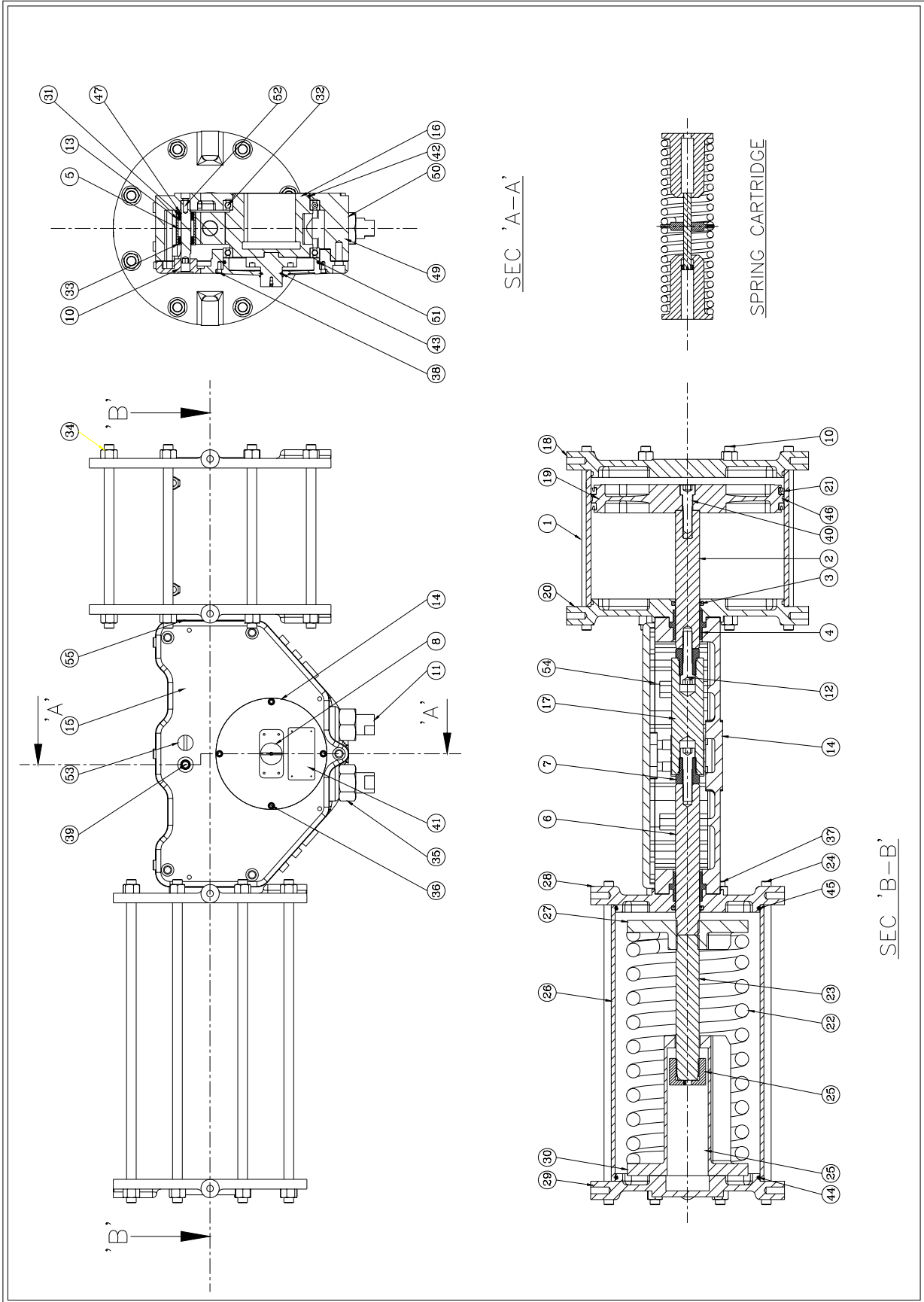

SR. NO.	DESCRIPTION	QTY.	SR. NO.	DESCRIPTION	QTY.
1	TUBE	1	29	E COVER REAR END	1
2	PISTON ROD	1	30	SPRING RETAINER REAR END	1
3	LIP SEAL FOR PISTON ROD	1	31	BEARING	8
4	BEARING BUSH	2	32	BEARING	2
5	SPACER	2	33	EXTERNAL CIRCLIP	1
6	CONNECTING ROD-1	1	34	HEX NUT	32
7	CONNECTING NUT	2	35	HEX NUT	2
8	PINION INSERT	1	36	HEX SOCKET HEAD SCREW	4
9	OFFSET ROLLER	2	37	HEX SOCKET HEAD SCREW	12
10	TIE ROD FOR CYLINDER	8	38	HEX SOCKET HEAD SCREW	4
11	STROKE ADJUSTMENT SCREW	2	39	HEX SOCKET HEAD SCREW	2
12	HEX SOCKET HEAD SCREW	2	40	HEX SOCKET HEAD SCREW	1
13	SLEEVE	1	41	NAME PLATE	1
14	CENTRE BLOCK COVER	1	42	O' RING	1
15	TOP COVER	1	43	O' RING	1
16	PINION	1	44	O' RING	2
17	RACK	1	45	O' RING	2
18	COVER REAR END	1	46	PISTON STRIP	1
19	PISTON ROD	1	47	INTERNAL CIRCLIP	1
20	COVER FRONT END	1	48	SPACER FOR HALF SPRING	1
21	LIP SEAL	2	49	CENTRE BLOCK	1
22	SPRING	1	50	O RING	1
23	CONNECTING ROD-2	1	51	O RING	2
24	TIE ROD	8	52	HEX SOCKET HEAD SCREW	1
25	NUT FOR CONNECTING ROD	1	53	PLUG FOR COVER	1
26	E-TUBE	1	54	GASKET 1	1
27	SPRING RETAINER FRONT END	1	55	GASKET 2	1
28	E COVER FRONT END	1			