

Electro-Pneumatic Positioner
RTX - Series

USER'S MANUAL

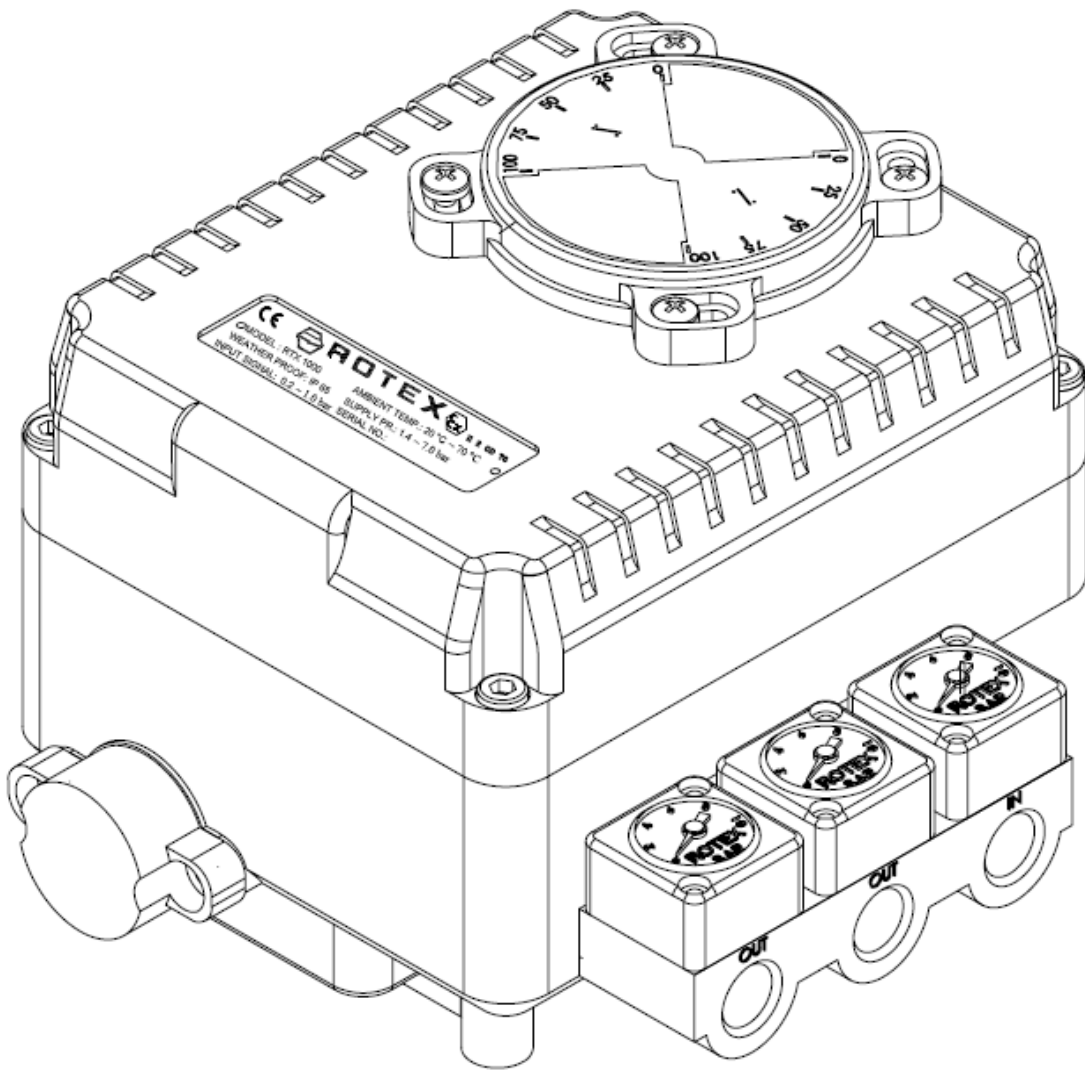

ROTEX E/P

Ver. 0.1

Dated: dd / mm / yy

Page 1 of 18__

Table of Contents	
Introduction	3
Manufacturer Warranty	3
General Service Information	4
Product Description	5
Label Description	6
Suffix Symbol	6
Specification	7
Parts and Assembly	8
Dimension	9
Safety Warning	9
Tools for Installation	9
RTX-1000 Installation	9
Bracket Information	10,11
Piping Connection	12
Supply Pressure Condition	12
Pipe Condition	12
Piping Connection with Actuator	12
Single Acting Actuator	12
Double Acting Actuator	13
Adjustment	13
Adjustment - Cam	13
Connection – Cable gland	14
Adjustment - Zero	14
Adjustment -Span	15
Adjustment - A/M Switch (Automatic/Manual)	15
Adjustment - Seat Adjuster	16
Adjustment – Orifice	16
Maintenance pilot Valve	17
Trouble Shooting	18
PTR assembly	19,20
PTR calibration	20,21,22

Introduction

Thank you for choosing ROTEX product. Each product is fully inspected after the production to offer you the highest quality. In order to fully utilize the product, we strongly recommend users to read this manual carefully and understood.

1. The manual should be given to the end user.
2. The manual can be changed or revised without any prior notice. Any changes in product's specification, structure, and/or any components may not result immediate revised version of the manual.
3. The manual should not be duplicated or reproduced for any purpose without any consent of Rotex Manufacturers & Engineers Private Limited., INDIA.

Manufacturer Warranty

- For the safety, it is vital to follow instructions in the manual. It is not ROTEX's liability for any damages which caused by users' negligence.
- It is not ROTEX's liability for any damages or accidents which resulted by any alteration or modification of the product and parts. If alteration or modification is necessary, please contact the ROTEX directly.
- ROTEX warrants the product from the date of original retail purchase of the product for one (1) year, except as otherwise stated.
- ROTEX warranty will not cover the products that the product have been subjected to abuse, accident, alteration, modification, tampering, negligence, misuse, faulty installation, lack of reasonable care, repair or service in any way that is not contemplated in the documentation for the product, or if the model or serial number has been altered, tampered with, defaced or removed; damages that occurs in shipment, failure due to power surge, and cosmetic damage. Improper or incorrectly performed maintenance or report voids this Limited Warranty.
- For detailed warranty information, please contact :
**ROTEX MANUFACTURERS & ENGINEERS PRIVATE LIMITED,
MANAPADA ROAD, DOMBIVLI (E), MAHARASTRA,
INDIA, PIN - 421204**

General Service Information

1. Service procedure is offered as a guide to enable general maintenance to be performed on ROTEX Pneumatic Positioner.
2. Normal recommended service interval under normal working condition for Pneumatic Positioner is five years. It may vary on usage performance ratio. Note:
Storage time is counted sad part of the service interval. Storage temperature (-20°C to +70°C).
3. This procedure is applicable with the understanding that all pneumatic pressure has been removed from the positioner.
4. Remove all piping & mounting accessories that will interface with the module (s) that are to be worked on.
5. This procedure should only be implemented by a technically competent technician who should take care to observe good workmanship practices.
6. Number in parentheses, () indicates the bubble number (reference number) used on the ROTEX assembly drawing.
7. When removing seals from seal grooves use a commercial seal removing tool or a small screw driver with sharp corner rounded off.
8. Use a non-hardening thread sealant on all pipe thread.
9. CAUTION:- Apply the thread sealant per the ROTEX's instruction.
10. ROTEX recommends that servicing of the positioner should be done in a clean area on a workbench.

Product Description

Main Features and Functions

- The product can operate normally in very extreme environment, such as vibration.
- The durability has proven after testing of 1 million times, at least.
- Response time is very short and accurate.
- Simple part change can set 1/2 Split Range.
- It is economical due to less air-consumption.
- Direct/Reverse action can be set easily.
- Zero & Span adjustment process is simple.
- Feedback Connection is easy.

Operation Logic

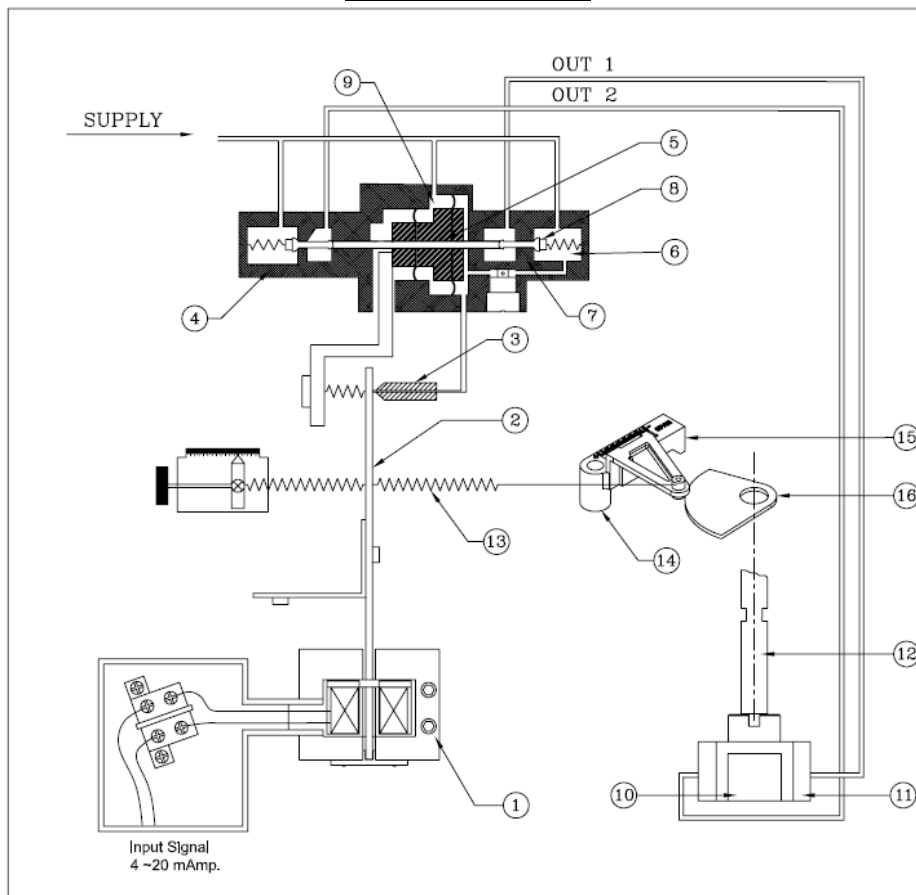

**RTX- 1000R
Fig. 1**

If supply pressure increased, flapper (2) gets pushed by the force from torque-motor (1). As the gap between flapper (2) and the nozzle (3) increases, air pressure exhausts from pilot valve (4) and upper spool (5). As a result, spool (5) rises,. Then the air pressure will be supplied to the actuator (10). As actuator (10) moves, the cam (16) receives the movement. This movement pulls the span spring (13). **Fig.1**.

Label Description

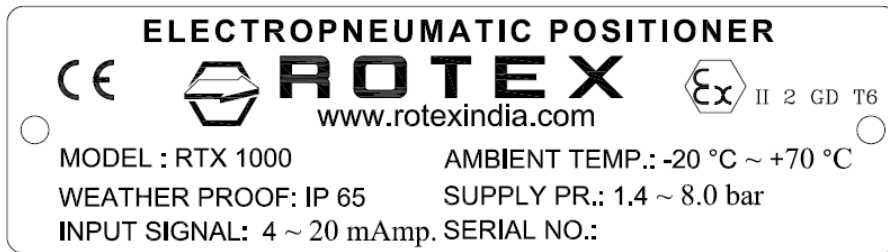

Model No.: Indicates model name and any options (if any).
 Input Signal: Indicates current input signal range.
 Supply Pressure: Indicates the range of supply pressure.
 Serial Number: Indicates unique serial number.

Suffix Symbol

RTX - 1000 series follows suffix symbol as follows.

RTX - 1000 1 2 3 4 5 6 7 8

1	Motion Type:	R	: Rotary
		L	: Linear
2	Acting Type:	S	: Single
		D	: Double
3	Orifice	0	: Nil
		1	: 1.0mm
		2	: 2.0mm
4	Feedback Lever	0	: Nil
		1	: 50
		2	: 100
		4	: 150
		5	: 200
5	Connection Type:	2G	: BSP
		2R	: NPT
6	Ambient Temp.:	0	: -20°C ~ +70°C
		1	: -20°C ~ +120°C
		2	: -40°C ~ +150°C
7	Indicator	FT	: Flat dome indicator
		HD	: High dime indicator
8	Accessories	0	: Nil
		1	: PTR Internal
		2	: PTR External (Explosion proof))
		3	: L/S Internal
		4	: L/S External (Explosion proof)
		5	: PTM + L/S Internal
6	: PTM + L/S External (Explosion proof))		

- For Special specification, please contact our sales department

Specification:

Category	RTX – 1000R	
Input Signal	4 ~ 20mA *	
Impedance	250 ± 15 Ω	
Supply Pressure	1.4 ~ 8.0 kgf/cm ² (20 ~ 120psi)	
Stroke	0 ~90° **	
Air Connection	PT (2G / 2R)	
Conduit Entry	PF 1/2 or G 1/2	
Explosion Proof	ATEX:	
Protection	IP 65	
Cam	Linear / Equal / SQ. / SQ. RT	
Ambient Temp.	Standard: -40°C ~ +150°C	
Linearity	± 1.0 % F.S	
Hysteresis	1 .0% F.S.	
Sensitivity	±0.2% F.S.	±0.5% F.S.
Repeatability	± 0.3 % F.S.	
Internal Bleeding	3.0LPM(Sup=1.4kgf/cm ² , 20psi),	
Flow Capacity	80LPM(Sup=1.4kgf/cm ² , 20psi)	
Material	Aluminum Die casting	
Weight	2.8 kg.	

* For Split Control, it can be applied by adjusting zero and span.

** For inquiry regarding strokes under 20mm, Pl. contact ROTEX.

- Test under ambient temperature of 20°C, absolute pressure of 760mmHg. And humidity of 80%. Please contact us for more detailed specification.

Parts and Assembly

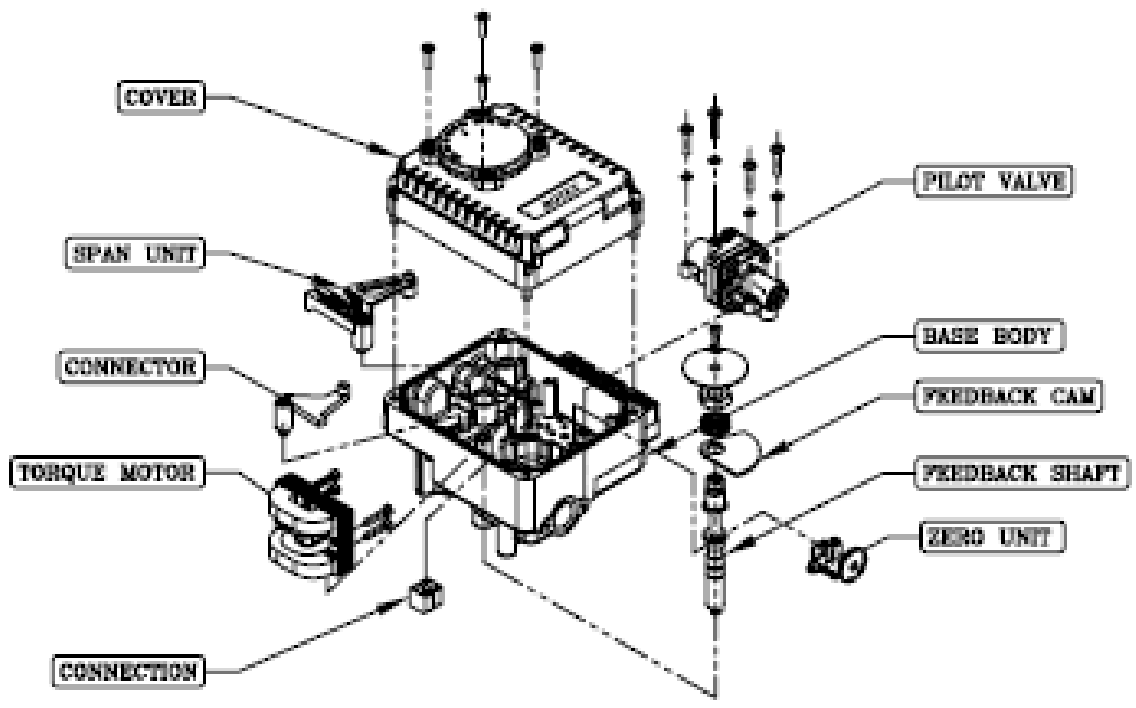
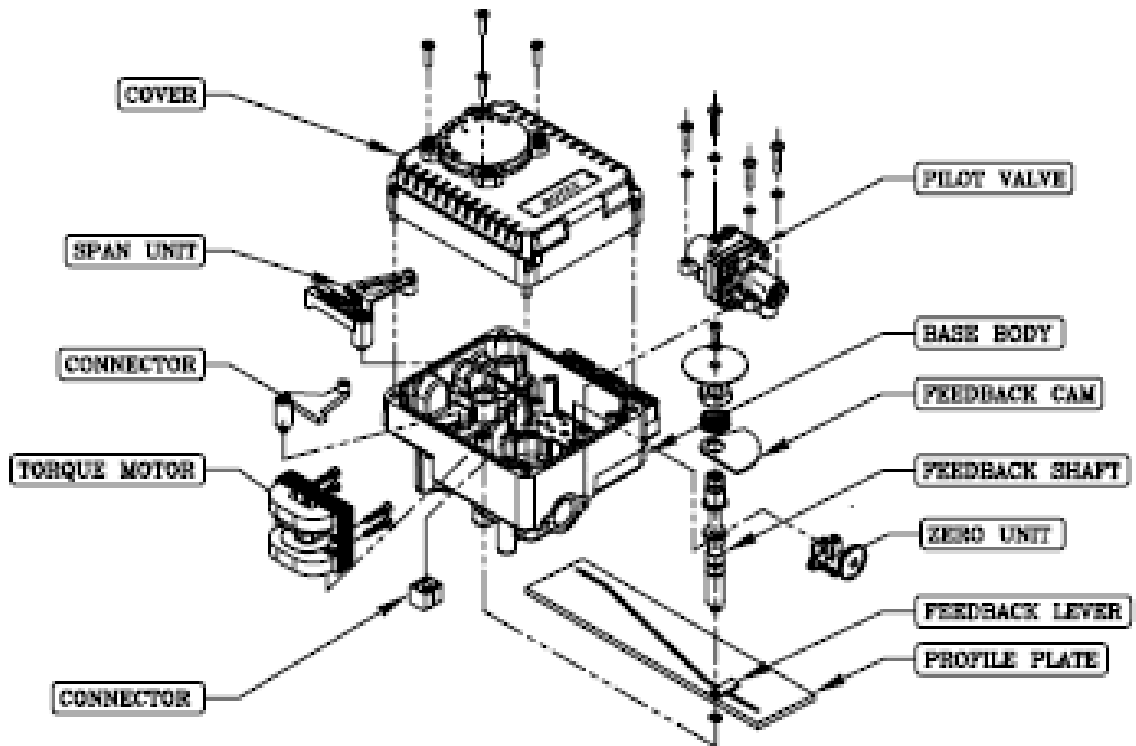

Dimensions

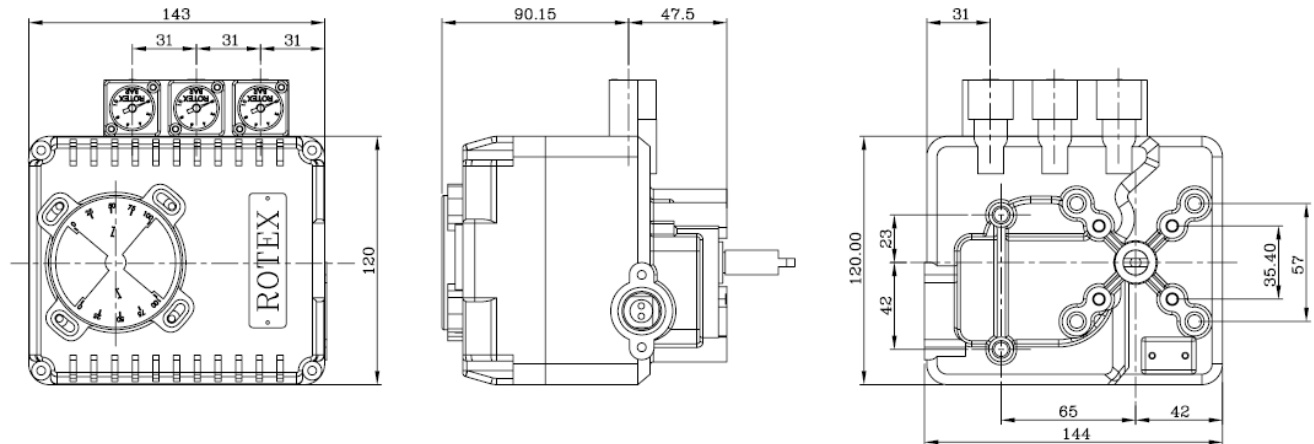

Installation

Safety Warning

When installing positioner, please ensure to read and follow safety instruction.

- All input and supply pressure to valve, actuator, and other related devices must be turned off.
- Use bypass valve or other equipment to avoid entire system "shut down."
- Make sure to exhaust air from actuator.

Tools for Installation

1. Adjustable wrench
2. Screw drivers (+) & (-)
3. Allen Key (5mm,4mm, 2.5mm, 2mm)

RTX – 1000R Installation

RTX – 1000R can be used for rotary actuator as well as linear actuator (Cylinder).

Rotary actuator motion valves are used for regulating ball valve, butterfly valve using rack and pinion, scotch yoke of complex type actuator, which its stem rotates 90 degrees.

And linear actuators are used to regulate the motion of dampers, In this arrangement we use a profile plate which converts linear movement of cylinder into rotary motion.

Be sure to check the following components before installation on rotary actuator.

1. RTX - 1000 main assembly
2. IOM
3. 1 Set of bracket (Not as a part of supply, needs to be order separately)
4. 4 Socket set screw
5. 4 Spring washer
6. 4 Hexagon head bolt

RTX – 1000R Install Layout on Rotary Actuator

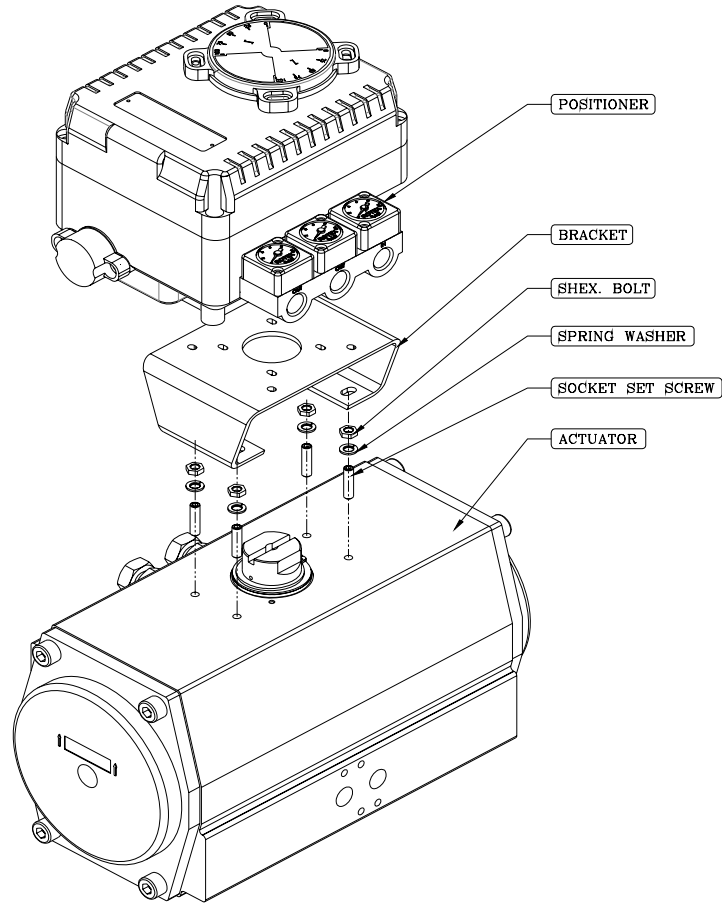

Fig. 2 (RTX – 1000R on Rotary Actuator)

Bracket Information

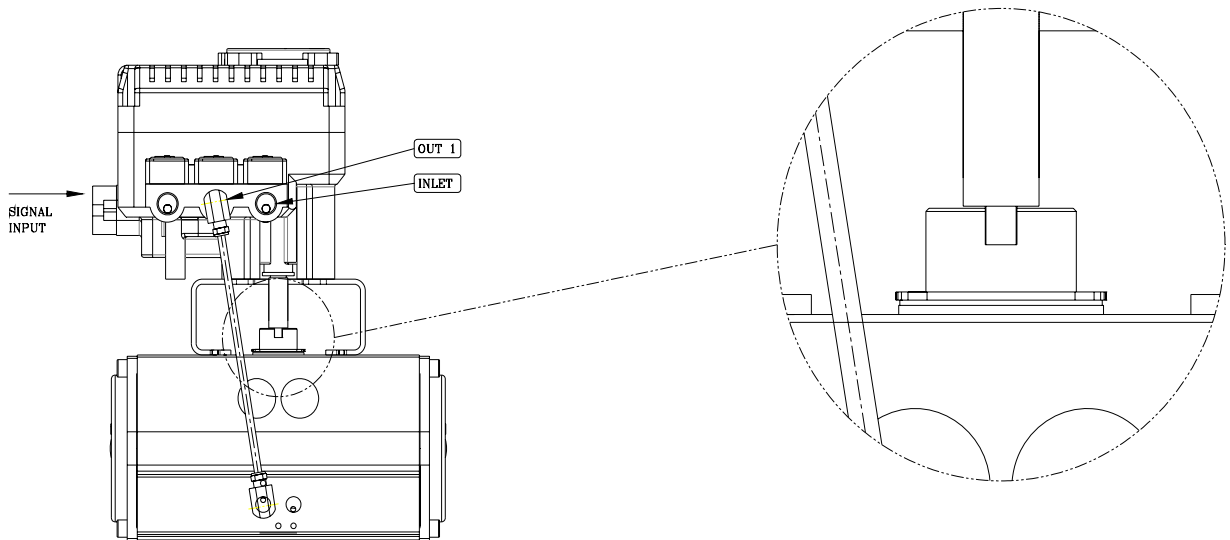

Fig. 3 (RTX – 1000R on NAMUR Shaft)

RTX - 1000 is supplied with standard bracket. Please see above Figure for more detailed information. Refer **Fig. 2**.

(1) Standard actuator stem height (H) is 20, 30, or 50mm. After checking "H", assemble with the bracket as shown in **Fig.3 & 4**. For bracket selection refer bracket selection chart in ROTEX positioner catalogue.

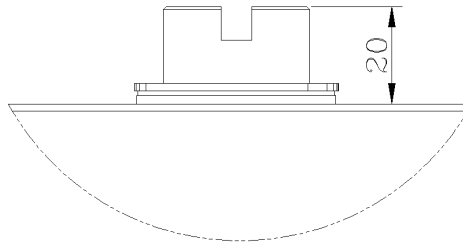

Fig. 4

(2) Attach bracketed RTX – 1000 to the actuator by using slotted screw and hexagon nuts. When tightening bolts, use spring washer or similar for firm attachment to the actuator, so RTX – 1000 have no effect by vibration or any other impact. The positioner is installed as shown in **Fig. 5**.

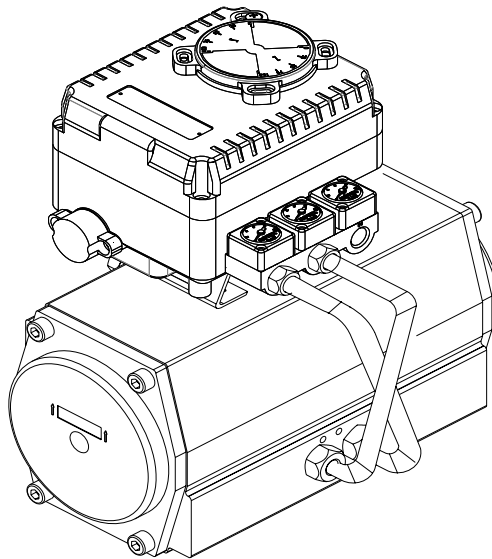

Fig. 5

(3) Set rotation position of the actuator stem at zero point, "0%." For a single type of actuator, it is easy to check zero point, because the actuator stem is positioned at zero point when there is no supply pressure. If double acting actuator is used, check actuator stem's rotation direction (clockwise or counter-clockwise) by supplying pressure.

(4) Tighten RTX – 1000 base and the bracket with hexagon-headed bolts and plate washer. It is recommended to tighten four bolts after checking RTX - 1000's position.

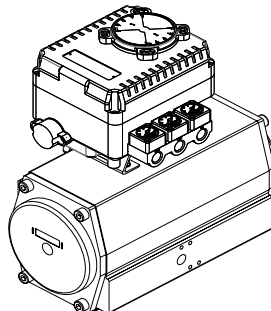

Fig. 6

Piping Connection

RTX – 1000 has a nozzle with a very small orifice; thus, use clean and less humid air in order to prevent extraneous material from mixing into the air. As per the filter, pay attention to filtration rating, flow rate, mounting position etc.

Note:

- To avoid entering moisture, oil, or dust into the product, please carefully make selection of supply pressure compressor.
- It is recommended to attach air filter regulator before supply port of RTX – 1000.

Supply Pressure Condition

- Dry air with at least 10°C lower than ambient temperature.
- Avoid from dusty air (5 micron filter provided)
- Avoid any oil.
- Comply with ANSI/ISA-57.3 1975(R1981) ISA S7.3-1975(R1981).
- Not to be used beyond the range of 1.4 – 8 kgf/cm²(140 – 700 kPa).
- Set air filter regulator's supplied pressure 10% higher than actuator's spring range pressure.

Pipe Condition

- Before piping, conduct air blow to clean the inside of the pipe to get rid of extraneous materials, powers etc.
- Do not use apparatus or joint which could cause leakage and resistance in the pipe.
- Do not use pipeline that is squeezed or has hole.
- To maintain flow rate, use the pipeline that has more than 6mm inner diameter.(10mm outer diameter)
- Do not use extremely long pipeline system. It may affect flow rate due to the friction inside of the pipeline.
- When connecting pipes be sure that sealing tape on adhesive does not mix with the pipes.

Pipe Connection with actuator

Single acting actuator

RTX – 1000R series single acting type is set to use OUT1 port. OUT1 port should be connected with supply pressure port from actuator when using single acting type of spring return actuator. **Fig. 7 & 8.**

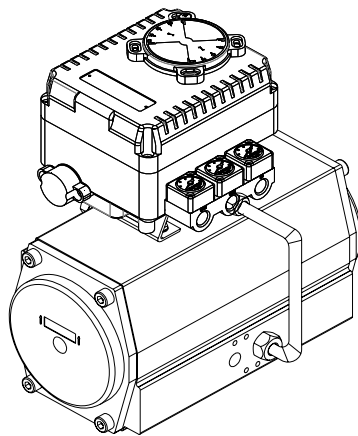

Fig. 7

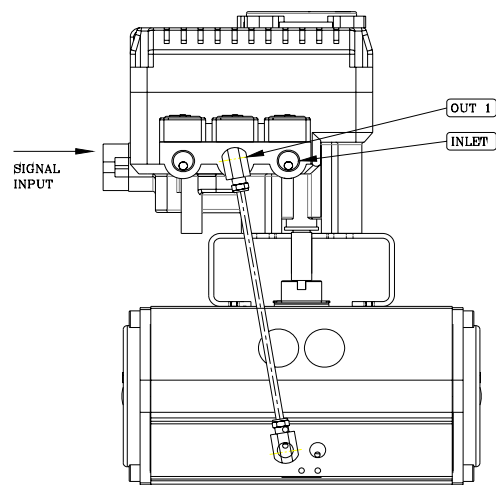

Fig. 8

Double acting actuator

For RTX-1000R series double acting type, when inputting current signal, supply pressure is out from OUT1. Please refer to **Fig. 9 & 10**.

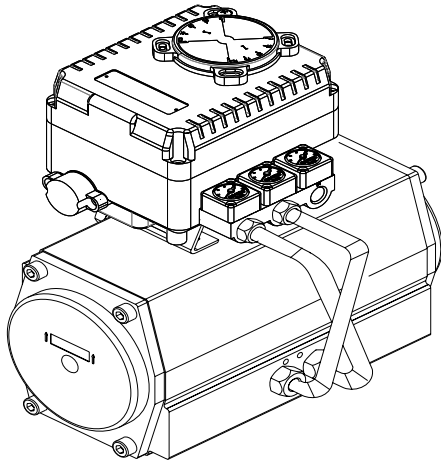

Fig.9

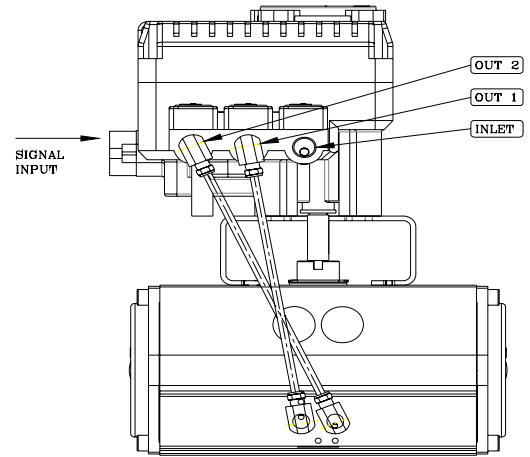

Fig.10

Adjustments

Adjustment – Cam

1. Direction of actuator's stem rotation must be checked when supply signal is supplied. When actuator's stem rotates clockwise, the face of cam must be shown "DA." On the other hand, when the stem rotates counter-clockwise, adjust cam so "RA" shows on the face of cam.
2. Check whether actuator's angle is at the initial point.
3. After checking the initial point, release the hexagonal flange nut and adjust the position of the bearing so it is at 0 point. **Fig. 11**
4. When produced, the cam is set as RA.

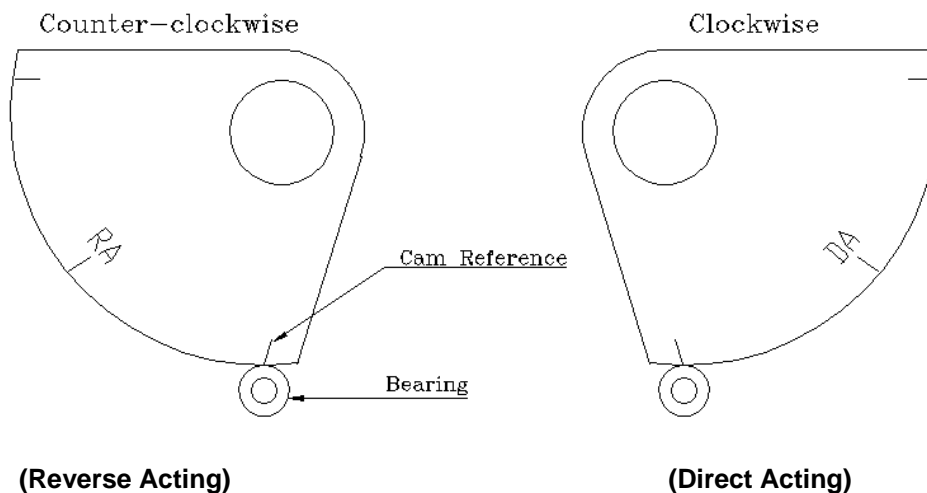

Fig.11

Connection – Cable Gland

1. Use certified explosion proof products.
2. End of cable must be crimp style terminal, Pl. refer to below table.
3. Insert the terminal connection into the housing completely.
4. Insert washer and rubber packing, and fasten the cable gland completely.

Connection – Power

1. Open positioner body cover.
2. Locate the poles and connect them properly. Make sure to fasten the connection.
3. Close the cover completely.

Safety warning.

1. Apply proper protection device to reduce frictions.
2. Protect the wires from damage.
3. Grounding must be done properly according to the field's procedures.

Connection – Ground

1. Open the positioner body cover.
2. Locate the poles and connect them.

Adjustment - Zero Point

1. Set supply signal at 3 psi and rotate adjuster clockwise or counter-clockwise to adjust actuator's rotation angle. **Fig.12**
2. When adjusting zero for single actuator, rotation angle is equal to positioner's pressure gauge.

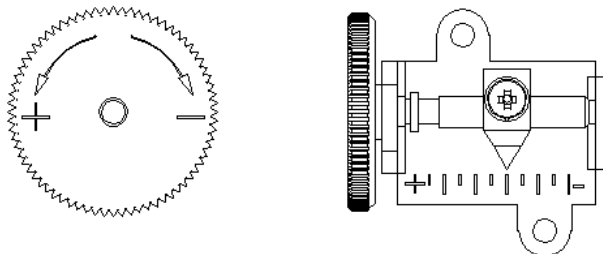

Fig. 12

Adjustment - Span

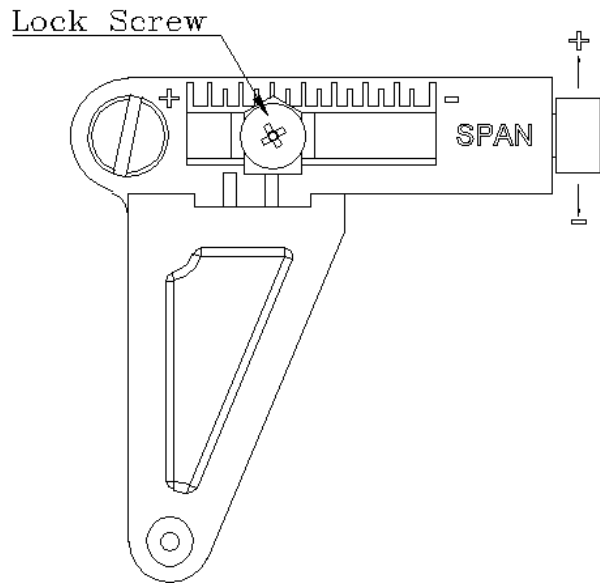

Fig. 13

1. After setting zero, rotate Span screw so supply signal reaches at the span point on the indicator.
2. Changing span point affects zero point setting. So zero setting must be set again. After setting zero point, confirm the span point. This step must be repeated until both points are properly set.
3. For RTX – 1000R with 1/2 split range, the span spring must be changed.
4. After setting is completed, tighten Lock Screw. **Fig.13**

Adjustment - A/M Switch (Auto/Manual)

1. A/M switch adjusts the valve operation to automatic or manual.
2. When produced, RTX-1000 series is set at "A(Automatic)". If user prefers the positioner's setting as "M (Manual)," the setting can be changed by turning the switch counter-clockwise. **Fig. 14**
3. If it is set as "M (Manual)", the air pressure will be supplied to the actuator directly. Always set back to "A (Automatic)" after setting change.
4. If OUT2 in single acting actuator or double acting actuator is used, A/M Switch will not operate. **Fig.14**

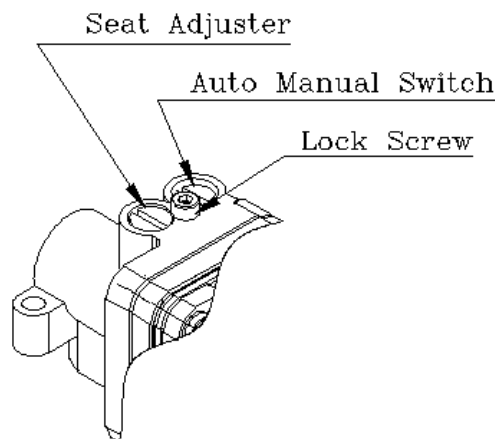

Fig.14

Adjustment - Seat Adjuster

1. Seat Adjuster is set according to the customer's request before the positioner is delivered. Please do not adjust the Seat Adjuster.
2. Seat Adjuster is used for double acting actuator always. Please do not touch the Seat Adjuster, because it can affect the positioner's performance.

Adjustment – Orifice

1. If the size of actuator is too small relative to the flow rate, positioner can have hunting. In order to avoid hunting, orifice can be used. There are three types of the orifice.

Actuator Size	Orifice Size	Suffix symbol
90cm ² less	Ø1.0	1
90 ~ 180cm ²	Ø2.0	2
180cm ² and above	None	3

2. Remove the o-ring from OUT1 and OUT2 port and insert appropriate orifice. After inserting orifice, place back the o-ring. Make sure there is no substance entering into port.
3. If hunting persists after inserting the orifice, please contact ROTEX or its appropriate agent.

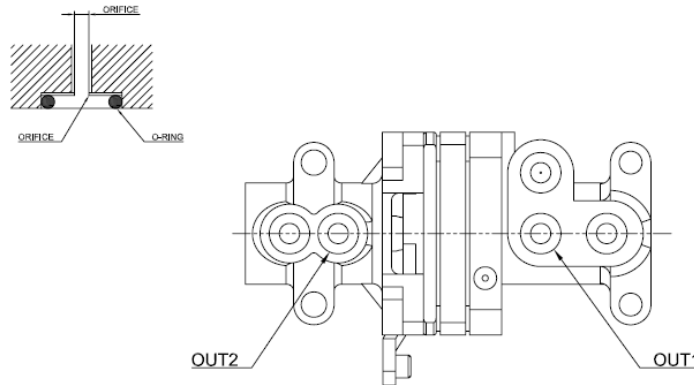

Fig. 15

Maintenance – Pilot valve

Maintenance should be performed on pilot Valve Relay at least once a year. When disassembling the pilot valve relay, please do make sure not to loose o-ring or stabilizer spring. Pl. refer to **Fig. 16** for the instruction.

1. Remove stopper bolt.
2. Unlock the Auto/manual Switch.
3. Remove if there is any blocking within the port and orifice.

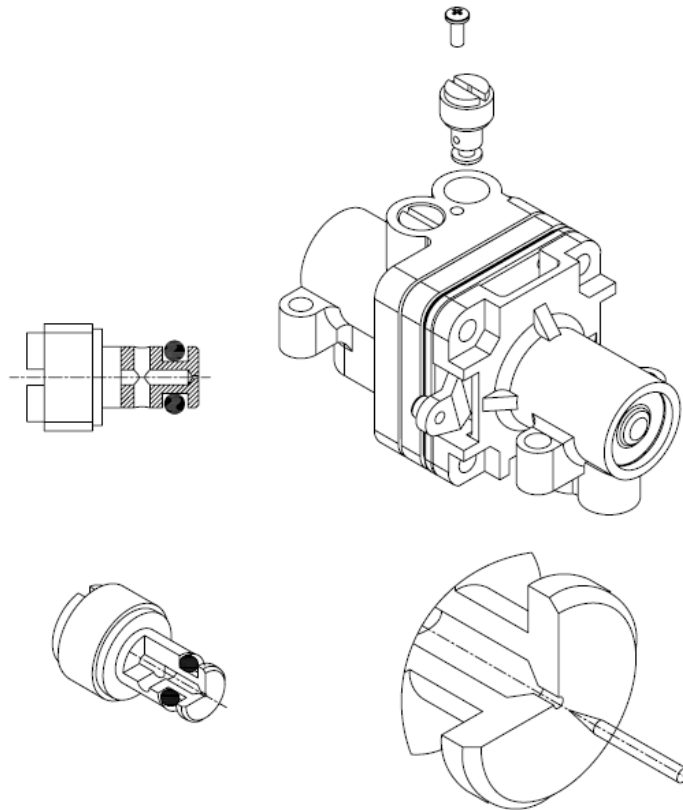

Fig. 16

TROUBLE SHOOTING

- **Positioner does not respond to the input signal.**
 1. Check supply pressure level. The level must be at least 1.4 kgf/cm².
 2. Check if input signal is properly supplied to the positioner. The signal should be 4~20mA DC.
 3. Check if the positioner's nozzle has been blocked. Also, check if the pressure is supplied to the positioner and the pressure is being exhausted through the nozzle. If the nozzle has been blocked by any substances, please send the product to ROTEX for repair.
 4. Check if feedback lever has been installed properly.
 5. Check if zero point or span point is properly set.
 6. Check if feedback lever has been installed properly.

- **The pressure of OUT1 reaches exhausting pressure level and does not come back down.**
 1. Check A/M Switch. If the switch has been damaged, replace the switch or pilot relay-valve.
 2. Check for a gap or damages between the nozzle and the flapper. If damaged, please send the product to ROTEX for repair.

- **The pressure is exhausted only by A/M Switch.**
 1. Check if the positioner's nozzle has been blocked. Also, check if the pressure is supplied to the positioner and the pressure is being exhausted through the nozzle. If the nozzle has been blocked by any substances, please send the product to ROTEX for repair.

- **Hunting occurs.**
 1. Check if safety spring has been displaced. (Next to Pilot relay valve)
 2. Check if the size of actuator is too small. If so, insert an orifice in order to reduce the pressure flow rate.
 3. Check if there is any friction between the valve and the actuator. If so, increase actuator's size or reduce the friction level.

- **Actuator only operates by On/Off.**
 1. Check pipe connection.
 2. Check cam direction.

- **Linearity is too low.**
 1. Check if the feedback lever is properly installed. Especially check if the feedback lever is parallel to the ground at 50% point.
 2. Check if zero and span have been properly adjusted, that is not too low or not too high.
 3. Check if supply air pressure level is stable from the regulator. If the level is unstable, replace the regulator.

- **Hysteresis is too low.**
 1. In case of double acting actuator, check if seat adjustment has been properly done. Please contact ROTEX for any further inquiries regarding the seat adjustment.
 2. Backlash can occur when feedback lever and lever spring is loosen. To avoid backlash, adjust the lever spring.
 3. Check if the connection bar to the feedback lever is tightly fastened.

PTR ASSEMBLY:

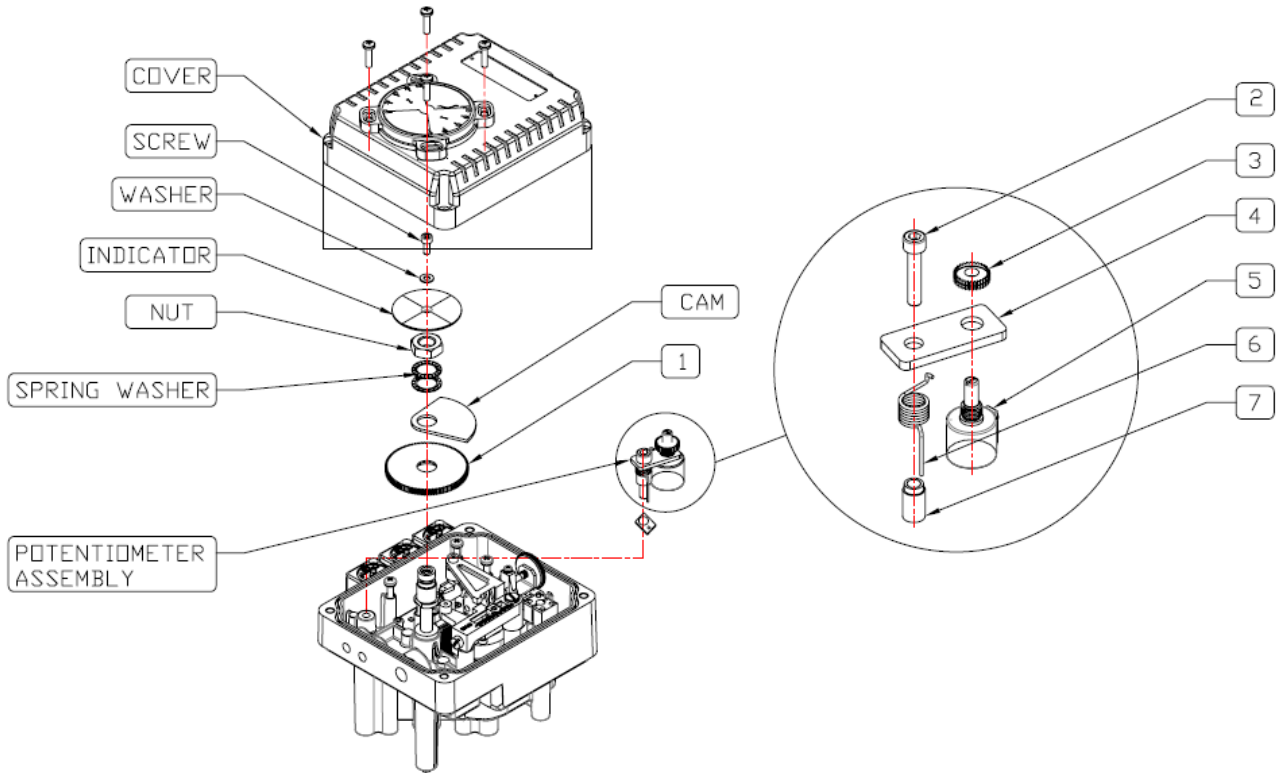

PTR BOM:

PART NO	DESCRIPTION	MATERIAL
1	GEAR FIX	ALUMINIUM
2	SOCKET HEAD SCREW	SS304
3	GEAR	ALUMINIUM
4	BRACKET	MS
5	POT	10K ohm
6	SPRING	SS304
7	BUSH	ALUMINIUM

PTR ASSEMBLY PROCEDURE:

1. Remove the cam unit from the shaft as shown in exploded view.
2. Now put the gear fix (1) on the shaft and assemble the cam unit.
3. Now tight the grub screw on the gear fix (1) with the help of hex. Key.
4. Fix the pot (5) with bracket (4) with nut provided.
5. Fix the gear (3) on pot stem with grub screw.
6. Insert the bush (7) into bracket (4), put spring (6) on bush (7) OD and lock it with bracket as shown in assembly.
7. Keep the gear (3) at pressure gauge side and screw entire assembly in positioner with screw (2).
8. Mesh the gear properly and lock the second end of spring (6) in positioner body.

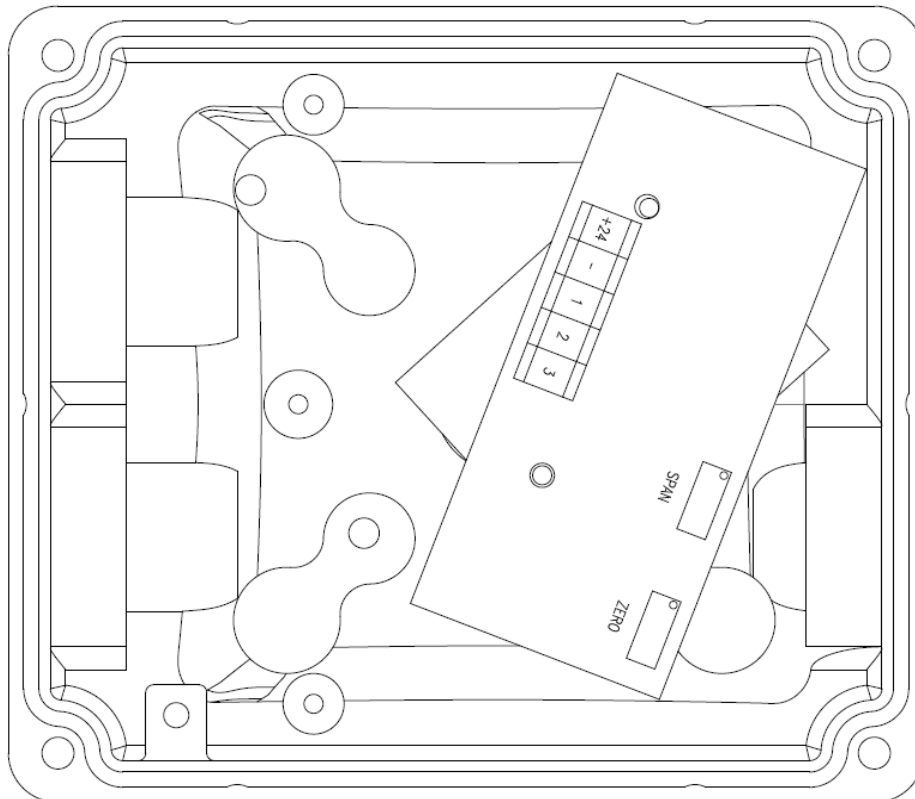

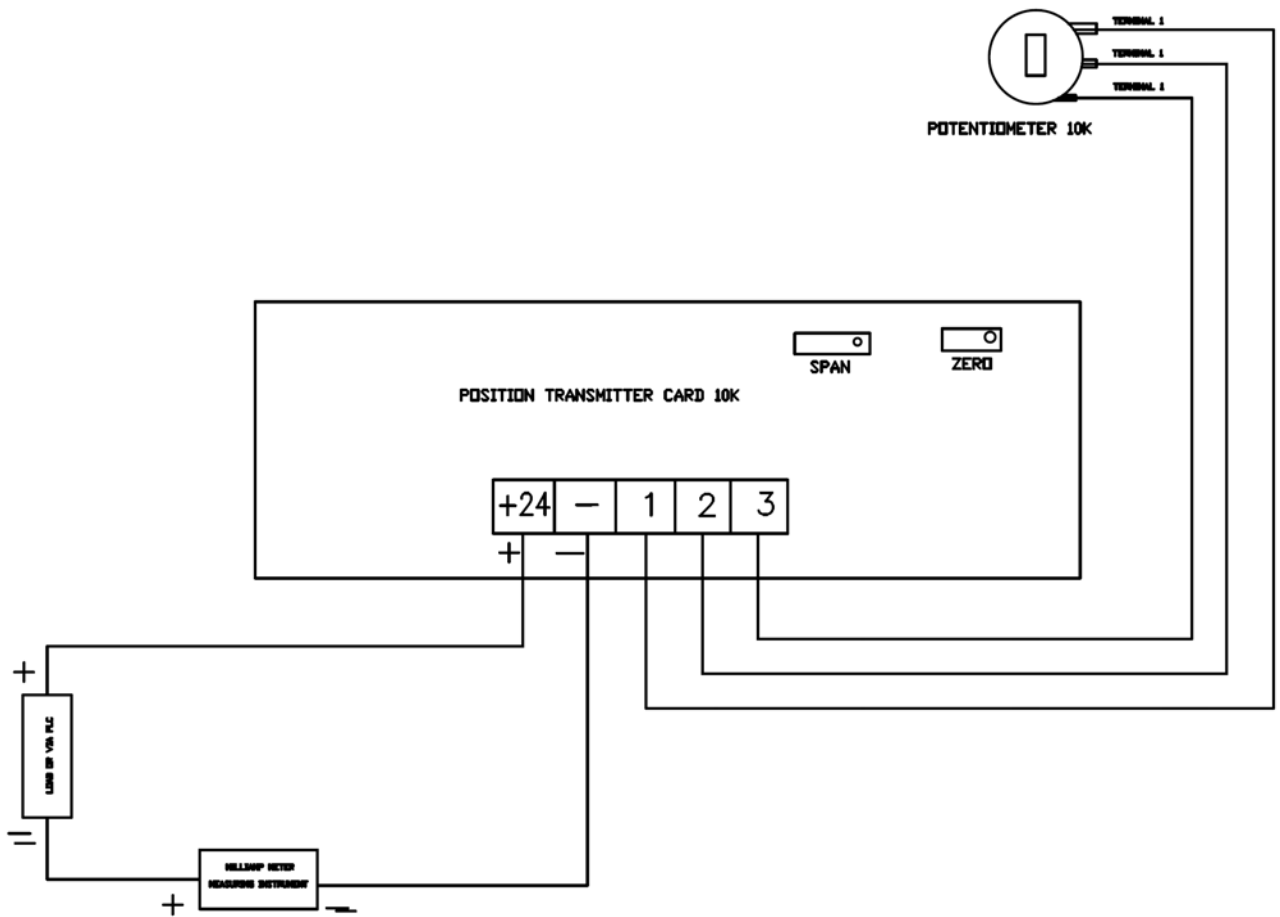

POSITION TRANSMITTER CALIBRATION

TOPIC 1:

Details for 5 pin pcb mounted dinkle connectors,

- 1) Positive loop (+24)
- 2) Negative loop (-)
- 3) Variable terminal 1 (1)
- 4) Common (2)
- 5) Variable terminal 2 (3)

TOPIC 2:

TRIM POT 10K SPAN: The trim pot 10k span is being used for adjusting 4-20mA span setting.

TOPIC 3:

TRIM POT 10K ZERO: The trim pot 10k zero is being used for adjusting 4-20mA zero setting.

TOPIC 4: OPERATING

LIMIT:

- 1) TEMPERATURE: 0-45 DEGREE CELSIUS (Operating more than that will give a non linear o/p)
- 2) MAX LOOP VOLTAGE: The loop voltage should be MAX 24v.

TOPIC 5: CALIBRATION

- 1) Set trim pot span towards its minimum position.
- 2) Set trim pot zero towards its maximum position.
- 3) To adjust for 100% scale reading adjust trim pot SPAN accordingly.
- 4) Check for linearity using the variable pot.
- 5) Again check for maximum o/p (mA) and adjust it to 20mA using trim pot SPAN.
- 6) Once the SPAN is set get the scale to zero and adjust the o/p to 4mA using the trim pot ZERO.
- 7) Check the linearity accordingly after the adjustment using the variable pot.
- 8) In case the minimum o/p is less than 4mA again adjust using trim pot ZERO to bring the o/p to 4mA.
- 9) Finally check for linearity using variable pot.
- 10) In case the linearity is not observed please follow the above steps to get the 4-20mA bracket.